

OCT/NOV 2023
Vol. 6, No. 5

Rollforming

Magazine

EXCLUSIVELY DEVOTED TO CONSTRUCTION ROLL-FORMING PROFESSIONALS
www.rollformingmagazine.com

OUT OF THE ASHES

MACHINES REBUILT AFTER
DEVASTATING FIRE

PORTABLE ROLL FORMING HISTORY ■ METAL SNIPS - A CLOSER LOOK
EMERGING ROLL FORMING TRENDS

METALCON
PREVIEW

THE COIL HANDLING SOLUTIONS YOU NEED TO MAXIMIZE EFFICIENCY & MINIMIZE WASTE.

SWI's Reliable, Fast & Easy-To-Operate Systems Ramp Up Any Sheet Metal Project.



Marxman Pro

The Marxman Pro is one of the most advanced sheet metal blanking systems on the market. **Automatic knife setup and auto nesting** ensure all jobs are processed quickly and with minimal material waste. And, with the Pro's part cut system, you can **part cut ANY slit, even in the middle of a sheet, with no damage to adjacent parts.** Or, when all parts are the same length, simply use the shearing blade to cut them all to length.

The Marxman Pro also comes standard with an **automatic labeling system**, which applies custom printed barcodes to each part, allowing you to move, scan, and load projects between slitter and folder with minimal downtime and reduced risk of operator error.

SWI Marxman Pro Automatic Slitter



SWI Coil Farm Technology – Decoiling & Storage

Coil Farm Technology – Decoiling & Storage

The first SWI coil farm system was installed nearly 10 years ago and hasn't missed a day of operation since. SWI now has a number of coil farm installations ranging from 8 to 22 coils. The original SWI ADSS (Automatic Decoiling & Storage System) was designed to facilitate efficient coil changes with minimal labor input. We're now excited to be developing **the next generation of SWI Coil Farm technology – the Coil Xpress.** The latest Coil Xpress design builds on the successful elements of the original coil farms and adds even more benefits, including **increased coil farm capacity** (more than 30 coils), **flexible floorplan options**, and even the ability to **operate two process lines on one coil farm.**

Right from the beginning, safety has been a key element of the SWI coil farm equipment, and it continues to be a focal point throughout the development of the next generation coil farms. Find out more about how our new coil farm technology is capable of beefing up your operation by reaching out today!

For Full Catalog or Quote:

(770) 766-0880 • info@swimachinery.com • SWImachinery.com



Artificial Intelligence: Garbage in, garbage out

■ By Karen Knapstein

In this edition, we've included something you've never seen in Rollforming Magazine before. You may have heard of Chat GPT in recent months. ChatGPT is an artificial intelligence (AI) text chatbot created by the OpenAI company. In late 2022, the chatbot was released as a free web-based tool. It processes information from a large database of online information and digitized books to mimic how people write.

People can ask it to generate articles, songs, poems, letters ... the list is nearly endless. It will come up with something to fulfil the request.

A while back, we asked ChatGPT, "Could you write a 1000 word article

on adjusting the dies on a roll forming machine for ag panel and do it in iambic pentameter?" The chatbot responded, "As an AI language model, I can certainly generate a 1000-word article on adjusting the dies on a roll forming machine for ag panel, but I'm not programmed to do it in iambic pentameter or any specific poetic form. However, I can try to generate a piece of writing that is rhythmic and follows a poetic pattern."

As you can see from its response above, it actually sounds like a *person* wrote it. And the poem that it generated sounds good to my ear ... I must admit poetry is not my forté; I'd never be able to create a poem like the chatbot did.

So will chatbots replace human writers

(and editors)? Maybe. But not yet. While it is adept at turning a phrase, it must be used with caution; ChatGPT's creations are frequently factually inaccurate — sometimes flat-out wrong. One reason this is the case: It uses information found on the web. As you well know, not everything found on the web is true.

I need your help: How accurate is the poem about adjusting dies? What did it get wrong? What did it get right? Send me your feedback before October 31 and we'll share it in the next edition.

Until next time — be well.

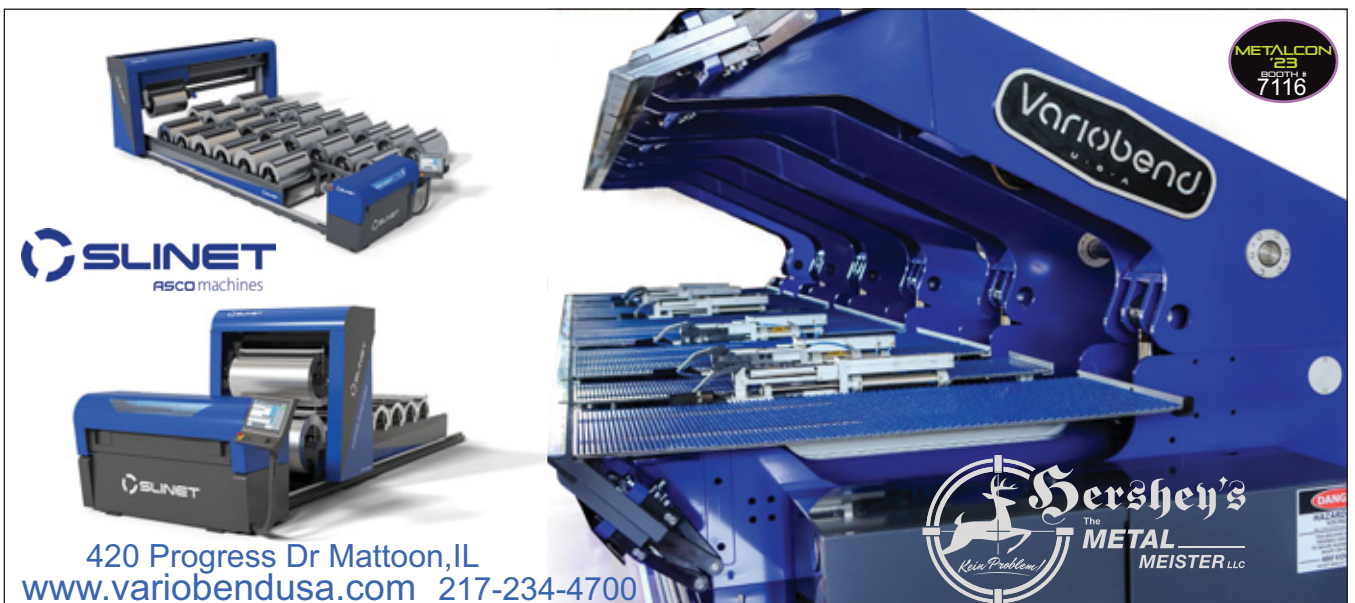
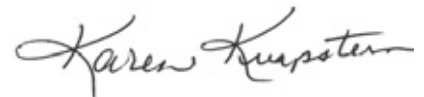

420 Progress Dr Mattoon, IL
www.variobendusa.com 217-234-4700

METALCON 2023 BOOTH # 7116

Hershey's THE METAL MEISTER LLC

Contents))

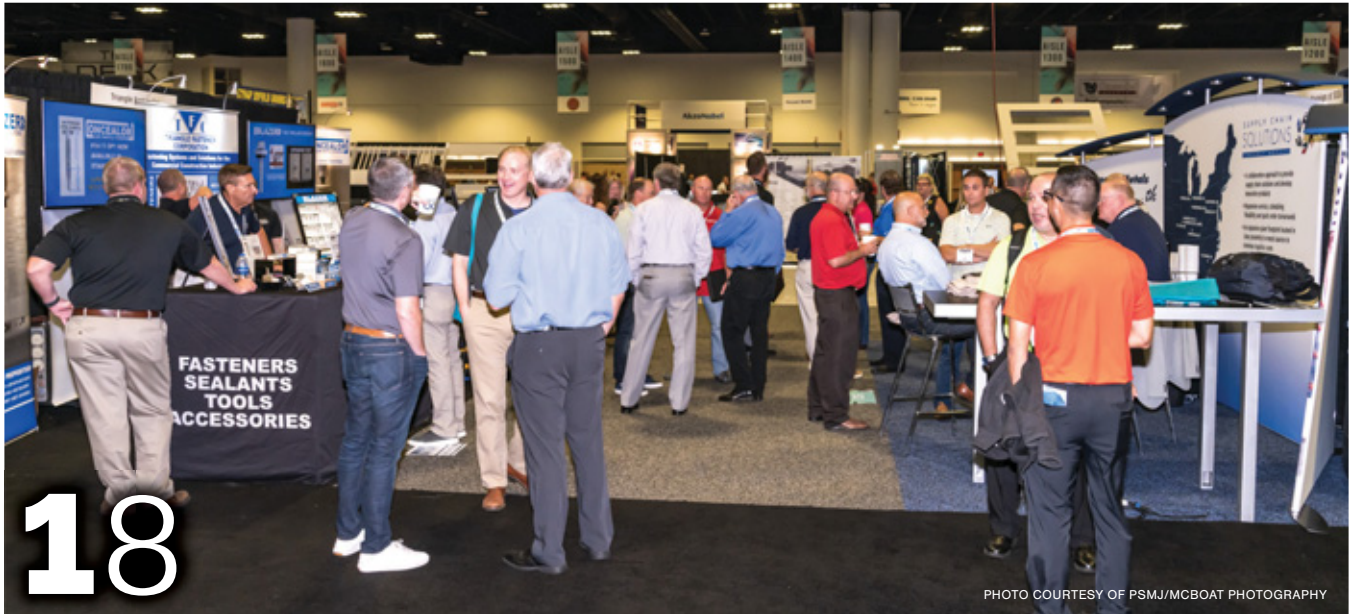

18

PHOTO COURTESY OF PSMJ/MCBOAT PHOTOGRAPHY



34

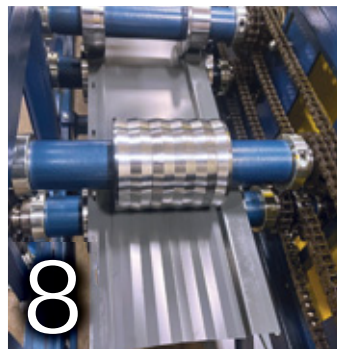

8



31

- 8:** Emerging Trends in the roll-forming industry
- 18:** METALCON 2023 Special show features
- 22:** History Lesson Portable roll forming
- 31:** Tools of the Trade A closer look at metal snips
- 34:** Up From the Ashes Equipment restored after fire
- 39:** MetalForming Get to know this supplier
- 42:** Special Feature A poem for roll formers
- 47:** Sunset Metals Pennsylvania roll former embraces opportunities
- 51:**  CONSTRUCTION SURVEY INSIGHTS Expansion plans across respondent categories

Departments))

- 3 Editor's Note
- 28 News
- 43 Business Connections
- 50 Products & Services
- 51 CSI

**GO TO PAGE 15 TO
SUBSCRIBE
TO MORE
FREE MAGAZINES**

YOUR PRIVACY IS IMPORTANT TO US

Unrelated third parties often attempt to sell mailing lists for what they say are our publications. You can be assured that WE DO NOT, HAVE NOT, AND WILL NOT EVER SELL OUR SUBSCRIBER LISTS. We will also NOT sell the attendee or exhibitor lists from our shows. We do provide attendee lists to the exhibitors free of charge and as a courtesy for their support, but we NEVER provide this or any other information to independent vendors.

Gary Reichert,
Publisher, Shield Wall Media

On The Cover:

A burned roll forming machine from Sunset Metals. *Photo courtesy of Acu-Form.*

INDEX OF ADVERTISERS

Company	Page #
AceClamp	37
Acu-Form	37, 44
Advanced Architectural.....	33
AkzoNobel	52
ASC Machine Tools Inc.....	29, 45
Atlas Fasteners	12
Aztec Washer Company.....	43
Beck Automation	33
Bradbury Group.....	27, 43
Daystar Systems LLC.....	43
Direct Metals Inc.....	41, 45
Drexel Metals	17
Dripstop®.....	11
Dynamic Fastener	9
East Coast Fasteners.....	25
Everlast Metals, Inc.	45
Formwright	36
Golden Rule Fasteners.....	43
Grabber Post Buildings, Inc.....	26
Hershey's Metal Meister.....	3, 44
Hixwood.....	49
I Beam Sliding Doors	43
JTS Sales	44
Kripke Enterprises (Mid South Aluminum)	13
Lakeside Fasteners	21
Leland Industries Inc.	45
Levi's Building Components	43
Little Harvey's	6, 7
Malco Products.....	32
Marion Manufacturing.....	38, 43
Metal Exteriors.....	45
Metal Rollforming Systems.....	35
On Top Safety Equipment	46
Pine Hill Trailers.....	45
Planet Saver Industries / GreenPost	44
Plyco Corporation.....	45
Red Dot Products, LLC	38
RetroFitClip.....	44
Roll Former LLC.....	40
Samco Machinery.....	43
Snap Z.....	41
Snow Stoppers LLC.....	45
Star 1 Products.....	28
SteelGrip SAMM, Inc.....	44
Stoll Metal Works.....	49
SWI Machinery.....	IFC
T&H Lemont	24
United Steel Supply.....	19, 44
Universal Tube & Rollform Equipment Company.....	44

Rollforming Magazine

Managing Editor:

Karen Knapstein
karen@shieldwallmedia.com
715-513-6767

Editorial Staff:

Linda Schmid, Rocky Landsverk,
Mark Robins

Circulation/Subscriptions:

Barb Prill
barb@shieldwallmedia.com
920-471-4846

Publisher/CEO:

Gary Reichert
gary@shieldwallmedia.com
715-252-6360

Director of Events:

Missy Beyer
missy@shieldwallmedia.com
920-216-3007

Executive/Advertising Assistant:

Kathy Budsberg
kathy@shieldwallmedia.com

Graphic Designers:

Tom Nelsen, Kevin Ulrich

Rollforming Magazine (ISSN: 2639-6742) (Volume 6, Issue 5) is published six times per year (March, May, July, September, November and December) by Shield Wall Media LLC, 150 Depot St., Iola, WI 54945. Periodical postage paid at Iola, WI, and at additional mailing offices. Canadian Agreement Number: 40665675. POSTMASTER: Send address changes to *Rollforming*, Barb Prill, PO BOX 255, Iola, WI 54945. Copyright 2023 Shield Wall Media LLC. *Rollforming Magazine* and its logo are registered trademarks. Other names and logos referred to or displayed in editorial or advertising content may be trademarked or copyright. *Rollforming Magazine* assumes no responsibility for unsolicited materials sent to it. Publisher and advertisers are not liable for typographical errors that may appear in prices or descriptions in advertisements. Mailed free to roll forming contractors and their suppliers throughout North America. Others may subscribe: \$19.98 for 1 year, \$36.98 for 2 years, and \$50.98 for 3 years.

Industry Partners



SEE PAGE 49



SEE PAGE 25



SEE PAGE 9



SEE PAGE 16



SEE PAGE 37



**BRADBURY
GROUP**
SEE PAGE 27



SEE PAGE 19



SEE PAGE 35



SEE PAGE 17



SEE PAGE 29

Next Issue:

- Construction Rollforming Show Report
- When To Start Roll Forming





Visit our website! permaguardpro.com

The Designer Coil

Advantages

- ✓ Heavy 26 GA. Substrate
- ✓ Kynar 500 Paint System
- ✓ Chalk and Fade Resistance
- ✓ Scratch Resistance
- ✓ Low Gloss Designer Finish

Perfect Choice for:

- Board & Batten
- Standing Seam
- High-end AG Panel

 888.202.0063

 4309@emailbyfax.com

 336.468.4309



Designer
Gray

Signature & Stack Stone



Sig. Weathered Wood

Sig. Natural Pine

Sig. Red Oak

Sig. Cherry

Stack Stone Shadow

Stack Stone Ash

NEW Textured Designer

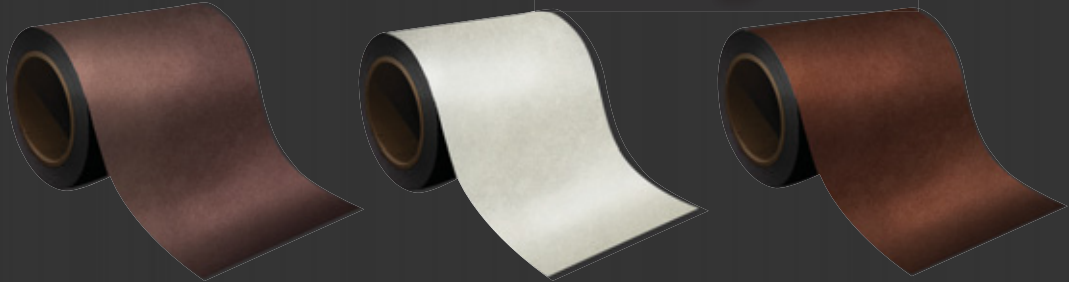

Designer Brown

Designer Almond

Designer Red

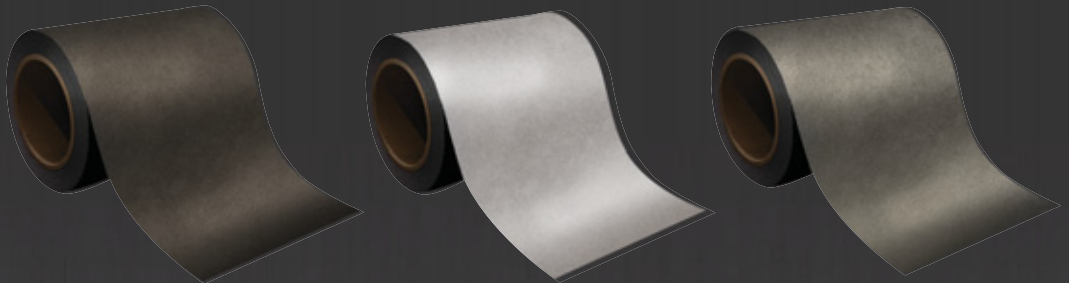

Designer Burnished Slate

Designer Clay

Designer Charcoal

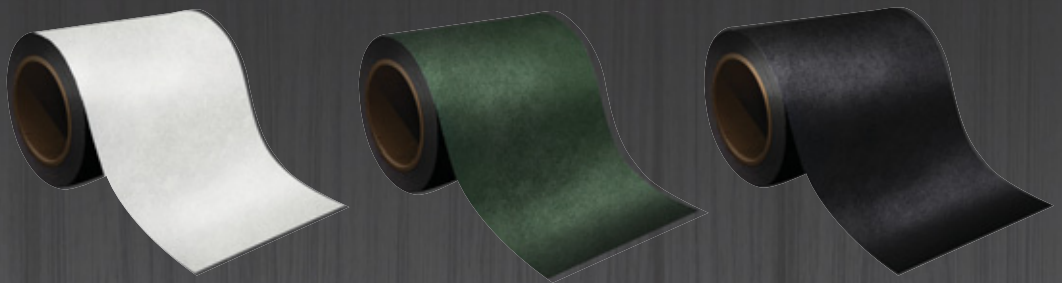

Designer White

Designer Green

Designer Black

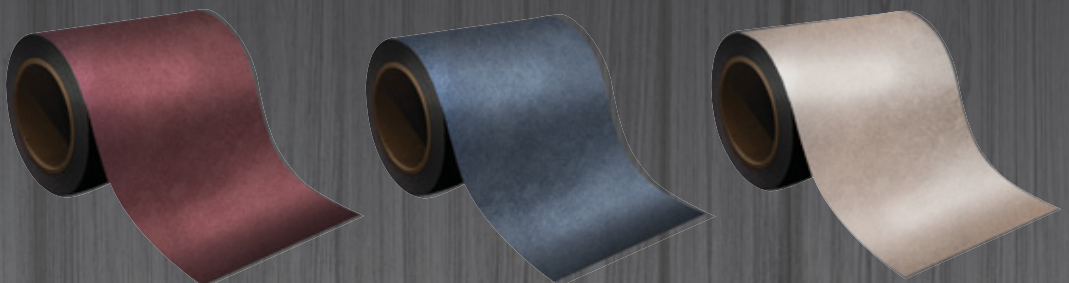

Designer Burgundy

Designer Gallery Blue

Designer Tan

Hot Trends

Board and batten, designer metals gaining popularity

■ By Sharon Thatcher

Metal board and batten siding, and designer metals with faux-finishes are two of the hottest trends in the roll-forming industry today. Neither category is new, but both have been experiencing exponential growth due to improved technology and increased roll-forming options.

BOARD AND BATTEN

Board and batten, a historical design originally used in wood, is a trend that first began to gain serious interest in the metal market about a half dozen years ago. It has continued to spread from the Midwest outward.

Trent Wagler with Graber Post Buildings, based in Indiana, reports that “board and batten has continued to blow us away with its gaining popularity. It truly has been a hit for residential projects, and rightfully so!”

Graber Post has been using a board and batten profile machine from Eastside Machine Co. for several years and has seen the style grow.

In North Carolina, Jesse Schlabach, whose family started in the shed business and has expanded into product development with a product called PermaGuard, is also seeing the trend. “We do see a lot of board and batten and a lot of customers are asking about it, becoming more aware of it. We see a lot of new houses going up with board and batten,” he said.

And in Colorado, New Tech Machinery has recently rolled out its own board and batten profile because of the expansion in consumer interest.

For anyone outside the market, a good definition of board and batten (B&B) is provided by Rick Zand for New Tech Machinery: “Traditional B&B is made



The Legacy Project in Greeley, Colorado, features a New Tech Machinery Board & Batten profile with the Steel Dynamics digitally designed Tru>Steel HD finish. PHOTO COURTESY OF NEW TECH MACHINERY.



Eastside Machine Co. saw the potential for board and batten in 1976. Today, it is one of 50 siding profile attachments available for its EM 6/8/10 roll former. EASTSIDE MACHINE CO. PHOTO

up of wide wood panels with a batten, or thin strip, that covers the seam. For metal B&B panels, the batten locks over the nail slots on the opposite end of a cojoining panel to replicate the look of the traditional style. The battens help protect the fasteners from damage or rust.”

It is popular with consumers looking for a traditional farmhouse look — often in white — but designers are also finding ways to incorporate it into modern designs. It looks great installed horizontally or vertically as exterior or interior

walls and accents.

Eastside Machine Company lays claim as the original manufacturer of a machine capable of producing a board and batten profile. The company first introduced a board and batten attachment for its portable seamless siding machine in 1976. It was one of three profiles the machine could produce at that time, but the board and batten took years to find its market. Eastside has seen its popularity increase substantially during the last four years. “While it used to be more irregular, we now sell a board and batten attachment with nearly every seamless siding machine purchased today,” the company noted, adding that it’s being used for both accent walls and complete exterior siding.

For a more authentic look Eastside has an exclusive self-contained embossing system that gives the siding a wood-grain look, plus adds strength and hides imperfections.

Metal Rollforming Systems (MRS) introduced its B&B profile in 2018 for its Patriot line, also adaptable to a hand-feed

DYNA-GUARD®



DYNA-GUARD® installed



DYNA-GUARD® on duty

S-5! We are discontinuing the line of S-5!® snow retention products. Closeout/below cost prices on S-5!®

- X-Clip™ II **\$2.75**
- X-Gard™ 1.0 Bracket **\$1.85**
- X-Gard 2.0 Bracket **\$4.50**
- S5S Stainless Mini Clamp **19.50**

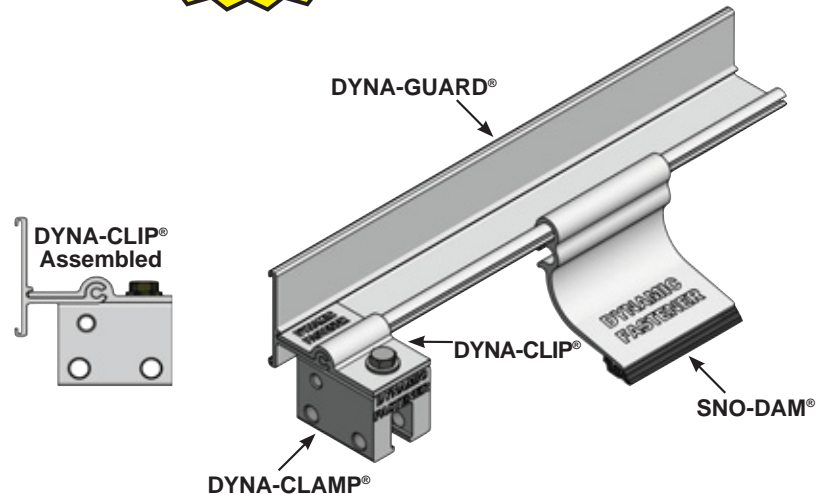
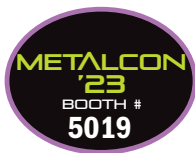

Our Dyna-Guard® Snow Retention System comes with a **free** 30-year warranty. Dyna-Guard®, Dyna-Clamps® & all related various connection points have undergone **extensive third-party testing** by the esteemed Encon Technology - Tulsa, OK

Attention architects / specifiers:

ARCAT For a CSI 3 part specification and CAD details on Dyna-Guard products see our page on Arcat

<https://www.arcat.com/arcatcos/cos50/arc50660.html>



DF ARCAT content

DYNAMIC FASTENER • 800-821-5448

S-5! is a registered trademark & X-Clip, X-Gard are trademarks of Metal Roof Innovations Ltd. DYNA-GUARD, DYNA-CLAMP, DYNA-CLIP, and SNO-DAM are registered trademarks of Dynamic Fastener Service Inc.

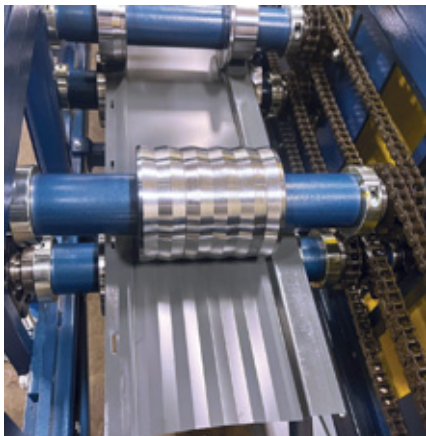

A striation pass being made on a board and batten panel on a Metal Rollforming Systems Patriot roll former. MRS PHOTO

trim line. Bill Griffin, President, said it was created using customer feedback and input during the initial design phase. “Our team of in-house engineers designed, tested, and refined the machine for 10 months before we felt it was ready for release,” he said. “At the time this was the first commercially available board and batten capable of utilizing 29- and 26-gauge, Grade 80 material.”

Not only was it an easy sell to the end consumer, but rollformers loved it because it allowed them to take advantage of their existing coil stock. Now, five years later, Griffin said, “We have seen continued success with the concealed fastener board and batten.”

New Tech Machinery introduced its board and batten profile for the SSQ II MultiPro Roof Panel Machine in early June of this year. It also fits older SSQ models dating back to 2014.

The New Tech board and batten profile will run .027” and .032” aluminum,



Closeup of the board and batten panel created using the New Tech profile for the SSQ II MultiPro and older SSQ models. NEW TECH PHOTO

or 24- and 26-gauge grade 50 steel. The panel width can run from 10” to 25 1/4”. The battens measure 2” wide by 3/4” deep with a 5/16” return. The batten locks over the nail slots on the opposite end of a cojoining panel.

But Wayne Troyer at Acu-Form says he is seeing the board and batten trend moving away from exterior use to the interior. In particular, he has noticed a trend in people perforating the B&B and using it on ceilings.



Metal Rollforming Systems reports that the popularity of board and batten has fueled the interest in other new profiles like this 5” double Dutch lap profile. MRS PHOTO

OTHER PROFILES GAINING ATTENTION

While board and batten has been turning heads, there’s recognition that other profiles are emerging. Bill Griffin, MRS, says this includes their double Dutch lap profile. “At the request of our customers, we’ve increased our offerings in these ‘designer’ profiles adding a through fastened option for reduced costs, and a 5” x 5” concealed fastener Dutch lap profile,” he said, adding: “The Dutch lap and the board and batten complement each other well, providing both a horizontal and a vertical solution for our customers.”

Customer demand for options is also driving development at Eastside Machine Co. “Everything different is hot. People don’t want just board and batten anymore,” said Brad Olson, Operations Manager at Eastside. “They don’t want to drive down the block and see the same thing over and over again. We often have

Other trends in the industry:

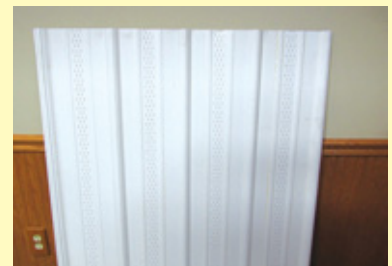

Wayne Troyer, Acu-Form, has noticed a trend in people perforating board and batten for ceilings, leading to higher demand for ag perforators. ACU-FORM PHOTO

HIGHER DEMAND FOR STAND-ALONE SHEARS, SOFFIT MACHINES, AND PERFORATORS:

Wayne Troyer, Acu-Form, said consumers want to color-match their metal roof and siding. This has resulted in increased demand in the roll-forming industry for soffit machines and perforators.

As a money-saving offshoot of that, Troyer said stand-alone shears are in high demand so damaged panel can be salvaged into shorter pieces for use as perforated soffit.

SNAP-LOCK ROOFING MACHINE:

Saving money is always popular, and Metal Rollforming Systems listened to its customers in developing the industry’s first 29-gauge, grade-80 snap lock roofing machine.

As President Bill Griffin noted, “This allows our customers to utilize existing coil stock to leverage purchasing power, while reducing material costs using 29 gauge instead of the traditional 26-gauge material. As most residential snap lock is installed over OSB or similar decking the importance of span rating is quickly negated by the cost savings. This combined with our pre-cut rib notching feature to expedite the installation process for the contractor have proven very popular both with our existing large national customers as well as our more regional roll-former customers.”



CONDENSATION CONTROL WHICH INCREASE PROFITS NOT LABOR COSTS

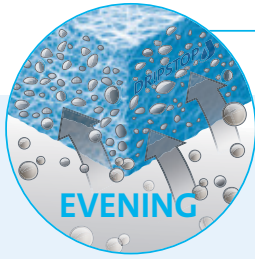

EVENING
Water vapor is absorbed between the fibers



Effective condensation control requires good building ventilation

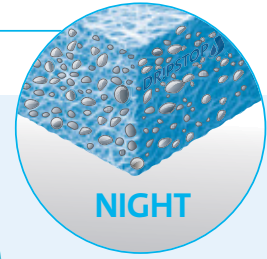
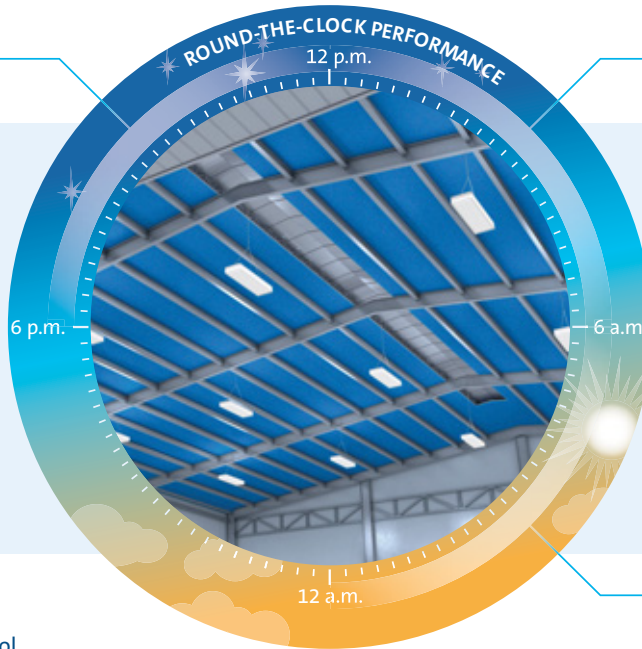

NIGHT
Moisture is trapped between the fibers

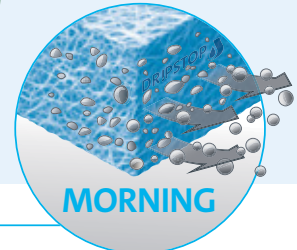

MORNING
Water evaporates through the roof opening

A Necessity for Any Metal Roofed Building That is Not Climate Controlled.

- Post Frame/agricultural buildings
- Workshops/unattached garages
- Steel buildings
- Open-walled structures
- Self-storage
- Carports, truck ports & RV storage

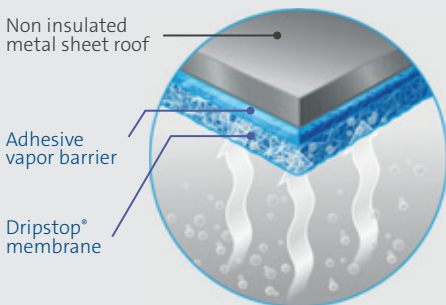

Better Science Equals Drier Buildings

When condensation occurs, moisture gets stored in the specially designed pockets of the Dripstop® membrane.

- Helps fight corrosion in livestock confinement
- Arrives on-site already on roof panels
- Cuts construction time in half
- Saves money

Fight Condensation Without Insulation

Ask for it from your preferred steel panel supplier

Write to us info@dripstop.com or call us at: 1-(937) 660-6646

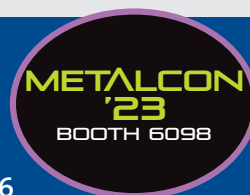

Get more information

Market Update))

four machines on a jobsite set up on different profiles and colors to give it a pop.”

Offering three profile options in 1976, today Eastside’s EM 6/8/10 Combo Seamless Siding Machine has more than 50 siding profile attachments available. These can be easily swapped out on the jobsite for unlimited options and flexibility.

“We are continually developing new profiles to meet the wants and needs of contractors, homeowners, architects, and builders,” said Derek Olson, Sales Manager for Eastside. “The variety of profiles Eastside offers makes it simple for contractors and architects to create an exterior aesthetic that stands out, which is what homeowners are looking for.”

PAINTED AND PRINTED COIL

Working in tandem with the popularity of profiles is the evolving science of patterned coil. Metal that is stamped, embossed, or digitized to show true patterns and textures is a game changer for the industry, especially as ways to provide longevity are discovered. This has been less problematic with simple textures, increasingly difficult for patterns that require more depth and multiple colors.

Achieving the realistic reproduction of natural textures on metal has been a goal



This building features white board and batten wall panel plus the use of the new Tru>Metal HD digital paint panel from Steel Dynamics on the beams of the front façade. GRABER POST PHOTO

in the contemporary coil industry for at least 10 years. It has been well received, but it has not been without its failures. There are ample examples of faux-finishes not holding up to the demands of nature or to expectations. Too many end users have been left with fading or chalky finishes, or walls with monotonous or unrealistic patterns.

But consumers, always attracted to low-maintenance solutions and the desire for something new and different, have kept the demand for better solutions moving the market forward. The greater success of subtle textures has now given way to bolder colors, and realistic brick, woodgrain, and stone.

This has worked well in tandem with

profiles like board and batten. Bill Griffin noted, “With the emergence of the new printed coil patterns like woodgrain, [board and batten] profiles are seeing a strong surge in the residential marketplace,” he said.

Wayne Troyer, Acu-Form, said he has also seen a rise in demand for the new printed and painted faux-finish coil. “Since they came out with the [look of] wood and brick [for coil], it has opened a whole different field. This is a game changer on all metal panels,” he said.

Using multiple colors, and mixing and matching colors, textures, and prints are also being explored by designers and consumers. Eastside, traditionally a manufacturer of roll-forming machines,



ASHLAND, OH
(800) 321-6977

FLAT ROCK, NC
(828) 629-2603

HOUSTON, TX
(800) 503-2105



FLAT TOP®

- HIGHER HEX PROVIDES POSITIVE SOCKET ENGAGEMENT
- SPECIAL UNDERCUT DESIGN ENTRAPS SEALING WASHER



#10 ULTIMATE®

- ZINC CAST HEAD WARRANTED AGAINST RED RUST FOR THE LIFE OF THE BUILDING
- SPECIAL UNDERCUT DESIGN CONCEALS WASHER

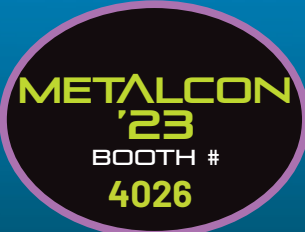

METALCON '23
BOOTH #
4026

ATLASFASSTENERS.COM USA MANUFACTURING & DISTRIBUTION TO SUPPORT YOUR BUILDING PRODUCT NEEDS

WE'RE ON A ROLL

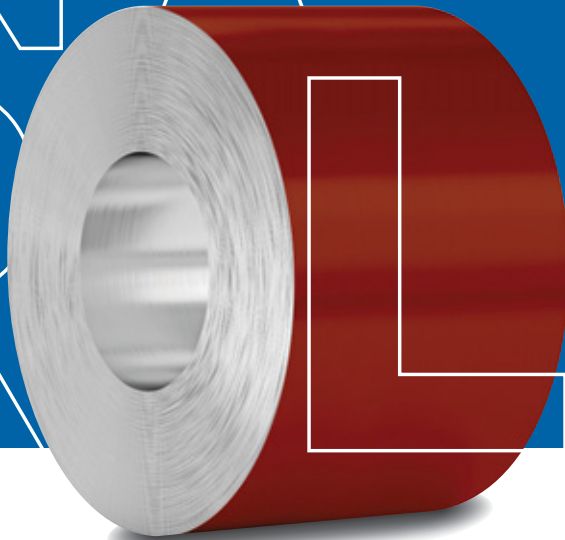

WE SPECIALIZE IN **PAINTED ALUMINUM COIL**

Like our coil, a relationship with Mid South is seamless and catered to your specifications. With over 25 years in the industry, we are painted aluminum coil experts down to our core.

Trust the specialists and let the good times roll.

TALK TO OUR SPECIALISTS

Alan Sallee Jr
Senior Vice President
731.736.4844

Courtney Friedman
Inside Sales
205.292.5697

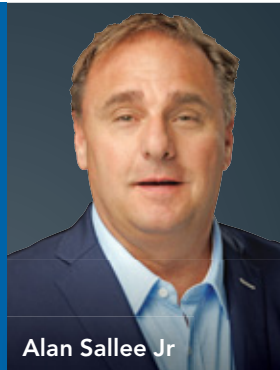

Alan Sallee Jr

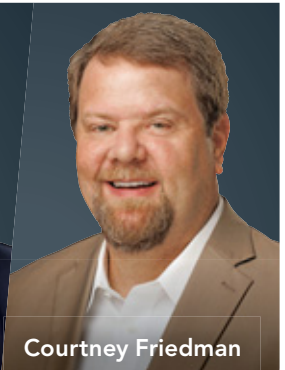

Courtney Friedman

731.664.2210
midsouthalum.com

MID SOUTH
ALUMINUM

feels confident enough in the science behind the new designer coils to offer them for their machines. According to the company, “This coil features a fade resistant Kynar 500®, Hylar 5000® paint finish, meaning even the deepest, most vibrant colors will retain their original look and resist chalk and fade, year after year.”

The first iterations of the most successful faux-finish metals were done with a paint and embossed roller process. A more recent generation of faux-finish metals uses digital printing. Both the embossed and digital reproductions are creating a real buzz in the marketplace.

One company investing in the goal to find a realistic, non-repeating design on steel is Steel Dynamics. Tru>Metal HD was introduced to *Rollforming Magazine* readers in the June/July 2023 issue. Graber Post Buildings helped Steel Dynamics develop realistic metal

patterns that are printed onto coil for the board and batten market. Tru>Metal HD, while not restricted to board and batten, has been particularly popular with the consumer.

“We are actually offering four wood grain options from SDI’s Tru>Steel HD,” Wagler explained. “We are still getting our feet wet with it, but it appears to be a hit! We received our first shipment of this material around January, and it has been extremely hard to keep enough inventory on the floor ... we are extremely excited to partner with SDI on this product.”

Wagler said Graber Post is still learning the ins and outs of the product and expects to be able to keep up with stocking demand after gaining more sales knowledge and data.

Other companies have also been exploring digital technology. This includes PermaGuard which has been in

product development for several years. It has also rolled out its product line earlier this year to wholesale partners.

Jesse Schlabach, part owner of PermaGuard, believes the next 10 years will expand greatly with new opportunities for designer metals. “In my opinion, there’s just this standard ag panel for 30 years and nothing has changed. Just in the last two or three years people started getting really innovative. Everybody is just becoming more aware with what you can do with metal, with prints, with different profiles. And it’s rapidly increasing. Personally, I say in the next 10 years there’s going to see a lot of change in metal cladding in as far as prints and profiles.” **RF**

Sharon Thatcher is the former managing editor of *Rollforming Magazine*. She is now an independent writer living in Ohio.

PermaGuard:

North Carolina company enters the designer-metals market

■ By Sharon Thatcher

It was in the shed-building business where the Schlabach family in Hamptonville, North Carolina, first saw the potential for designer metals. Their company, PermaGuard, is now one of the innovators in the rising market of designer coil.

PermaGuard offers rustic patterned coil directly to rollformers produced two different ways: one using the embossing process plus a Kynar 500 finish for longevity, and one using a digital process plus Kynar 500 finish.

“What sets our digital print apart is the fact that we use a Kynar 500 Ink System, and finally we protect the whole system with a Kynar 500 Clear Coat. This is very



This barn was built using designer metals from PermaGuard. PERMAGUARD PHOTO.

SUBSCRIBE NOW!



Shield Wall Media brands are dedicated to serving the information needs of construction professionals.



SUBSCRIBE ONLINE: shieldwallmedia.com/subscribe or fill out & mail form below.



FREE 3-YEAR SUBSCRIPTIONS!

1. Please check one or more boxes, sign & date:

I wish to receive: Metal Roofing Garage, Shed & Carport Builder Metal Builder
 Rural Builder Frame Building News Rollforming Roofing Elements

Signature (REQUIRED): _____ Date: _____

Print Name: _____

Company: _____

Address: _____

City/State/Zip: _____

Phone or Email (REQUIRED): _____

Check this box if you wish to receive the email newsletter associated with the magazine subscription(s) above.

2. Choose which title applies:

- President/Vice President
- Principle/Shareholder
- Sales Manager or Rep
- Foreman/Crew Manager
- Engineer/Architect
- Other: _____

3. Describe your business:

- Builder/Contractor
- Dealer/Distributor
- Manufacturer
- Engineer/Architect
- Other: _____

I would like to receive my subscription:
 By Mail
 Digitally

SWM2023

4. Please check all of the types of building or manufacturing you are involved with:

- | | | | |
|---------------------------------------|--------------------------------------|---|---|
| <input type="checkbox"/> Post Frame | <input type="checkbox"/> Residential | <input type="checkbox"/> Metal Roofing | <input type="checkbox"/> Rollforming |
| <input type="checkbox"/> Metal Frame | <input type="checkbox"/> Commercial | <input type="checkbox"/> Trusses/Columns | <input type="checkbox"/> Trim & Flashings |
| <input type="checkbox"/> Fabric | <input type="checkbox"/> Equine | <input type="checkbox"/> Foundations | <input type="checkbox"/> Insulation/ |
| <input type="checkbox"/> Agricultural | <input type="checkbox"/> Roofing | <input type="checkbox"/> Gutters/Snow Retention | <input type="checkbox"/> Moisture Control |



MAIL TO:
 Shield Wall Media
 ATTN: Barb Prill
 PO Box 255, Iola, WI 54945

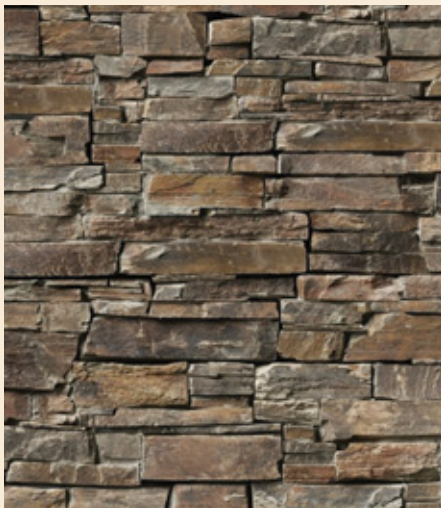

Samples of just three of the various designer metals available from PermaGuard: l-r: Stack Stone in Ash color, Signature Red Oak, and Designer Burgundy. PERMAGUARD PHOTOS.

important in the digital process as digital prints typically fade rapidly,” said part-owner Jesse Schlabach.

The Schlabach brothers began their pursuit for quality finishes in metal when they became dissatisfied with wood and the common problems of warping and cracking in treated wood lap-siding. “We were looking for a product to replace wood without having all those problems,” Jesse said.

They looked at metal, “but people wanted something that didn’t look like a common metal shed,” he said.

They looked at printed wood patterns on metal, only to be unhappy with many of the systems on the market. They noticed two common problems: No. 1, the lack of depth and definition, and No. 2, to keep costs down, too many options utilized cheap paint systems that lost their looks in 5-10 years. “If you picked up a sample of it, it looked okay, but when you put it on a wall and backed off, the print disappeared,” he explained.

The Schlabachs wanted something better. “We wanted something that really popped; something where you could still see the woodgrain if you backed off 100 or 200 feet,” Jesse said.

So, they started developing their own. “It was several years to develop it, a lot of trial and error,” he said. “We started [using it on] sheds, and that worked out

really well, then expanded to pole barns.”

Their commitment included developing their own roll-forming shop, originally to supply only their shed-building business. Reception for the faux-finish metals was so successful they opened it up for wholesale to other rollformers beginning this past January. “We sell from Montana to Pennsylvania, and we also have a small roll-forming shop [in North Carolina] where we supply local contractors,” he said.

They run two double decker roll-forming lines with machines from ASC Machine Tools. “We’ve had great success with them,” he said of the ASC machines.

They offer five different woodgrain metals created via the embossed process, and two stack-stone options created via the digital process, plus 13 solid colors with variegated texture for board and batten and standing seam.

The embossed process has a well-established track record for longevity, but is a repeating pattern, so to compensate, PermaGuard has selected patterns that are less noticeable of the repeat. They have seen it effectively used on high-end horse barns and homes. “That’s a true Kynar paint system where you get a true Kynar paint warranty out of it,” he said, “so it doesn’t fade or chalk for 30 or 40 years.”

Still, the repeatability of an embossed product prompted the Schlabachs to

continue their search for something even more realistic. They are working with a digital partner to create designs that are printed but will not fade quickly. “We don’t want to put a digital product out there that will wash out,” Jesse said. He is confident they are on the right path to get there largely due to the use and track record of the Kynar 500 Clear Coat. They start with heavy-duty 26-gauge metal coated with a base coat of AZ50 Galvalume, then a primer coating, a layer of Kynar 500, then the print layer, followed by a clear coat finish.

At present, their digital finishes are only used on their stack-stone series. “These panels are typically used for wainscot and porches and will receive less sunlight,” Jesse said, “but with the Kynar 500 Ink and Kynar 500 Clear Coat we are confident that it will stand the test of time.”

Although Jesse thinks wood prints will take up a small percentage of the metal market overall, it has appeal in rural areas such as farmlands, mountains, and woodlands “for people who just want that wood look, but they don’t want the maintenance.” **RF**

 For more titles, check out
Shield Wall Media online:
www.shieldwallmedia.com



THE DM-ARM HAS YOUR BACK!

Drexel Metals Association of Regional Manufacturers (DM-ARM) is a comprehensive portable roll former program designed to help you meet building codes and build your brand locally. The Drexel Metals DM-ARM program allows installers and regional manufacturers to grow their businesses by offering better local control, greater profits, freight savings, less scrap, and the ability to provide metal roofing on-demand.

As a DM-ARM member, Drexel Metals becomes your “back-office partner”, allowing your team to spend more time in the local market!



Become a member at
www.drexmet.com.



Learn more at www.drexmet.com

Sell More with the Roofing Passport

Exclusive to DM-ARM members, the Sherwin-Williams® Roofing Passport is a groundbreaking platform that simplifies metal roof estimation and ordering. As a fully automated program, this digital platform enables project estimation in one click. The Sherwin-Williams Roofing Passport creates a powerful link between EagleView's highly accurate roof measurements and SmartBuild's automated estimation software, creating an easy-to-use bidding platform.

1234 Gardiner Lane | Louisville, KY 40213
drexelmetals.com | Toll Free: 888-321-9630 | Fax: 877-321-9638

Drexel Metals 
Roofing Systems + Custom Fabrication
A CARLISLE COMPANY

METALCON 2023

Highlights & Educational Programming at the Las Vegas Convention Center

METALCON announces its program lineup for this year's annual conference and tradeshow scheduled from Wednesday, Oct. 18 to Friday, Oct. 20 at the Las Vegas Convention Center.

From intensive pre-show workshops beginning on Tuesday, Oct. 16 to 35+ free educational sessions conveniently located inside the exhibit hall to inspiring keynotes, top industry experts will share their knowledge with attendees who are eligible to earn nearly a year's worth of continuing education credits (CEUs), including AIA learning units among others.

The only global event dedicated exclusively to the application of metal in design and construction is brought to you by 2023 sponsors: Mill Steel Company (premier level), CIDAN Machinery Inc., (platinum level), US Steel (diamond level) and others, along with long-time partner, the Metal Construction Association (MCA).

Keynote speakers for this year's show include contractor and Denver business owner Rico León, HGTV host of "Rico to the Rescue," presenting "HGTV's Rico to the Rescue: Real Life Scenarios — From Nightmares to Dreams Come True" on Wednesday, October 18 at 10:00 a.m. He will share some of his most unforgettable experiences and lessons learned from residential construction projects gone wrong and then turned around.

Then, on the following day at the same time, Ken Simonson, chief economist of the Associated General Contractors (AGC) of America, with 40+ years of experience analyzing, advocating and communicating about economic and tax issues, will explore the current state and outlook for construction in his keynote, "Construction Outlook for 2024: Forbidding or Reason for Cheer?"

A variety of special focus areas are planned, including:

THE ARCHITECT'S EXPERIENCE

Back for a third consecutive year and brought to you by PPG Industries, this "show-within-a-show" over two days is focused on the use of metal as a design and construction component,



METALCON returns to the Las Vegas Convention Center in October. PHOTO COURTESY OF PSMJ / MCBOAT PHOTOGRAPHY

specifically to help architects, designers, specifiers and engineers solve tough architectural, structural, environmental and building performance challenges.

Offering exclusive education sessions specific to design professionals, attendees will hear from respected thought leaders, award-winning architects and industry experts, including featured keynote morning kick-off sessions. On Wednesday, October 18 beginning at 8:30 a.m., Christopher Sotiropoulos, vice president of stadium operations joins Gary Edgar, manager of architectural specifications and industrial coatings of PPG to present "Designing for Las Vegas: A Full House of Finishes for Allegiant Stadium to Enhance, Protect & Cool." Sotiropoulos will share what it took to build — and maintain — this \$1.9 billion stadium as well as its ongoing sustainability initiatives.

Then, the next day at the same time, architect and author Stefan Al will delve into the world of architectural innovation and its profound impact on skylines worldwide in his keynote, "Steel and Skylines." Drawing from his acclaimed book "Supertall," Al will share insights from the realm of skyscrapers, shedding light on the emergence of a new generation of towering structures that defy conventional limits in terms of height and design. Additionally, he will highlight the unceasing evolution of Las Vegas Boulevard as he explores the developments of resort design contributing to the city's distinctive character. Based on his book "The Strip: Las Vegas and the Architecture of the American Dream," he uncovers the dynamic changes that have shaped this iconic destination while contemplating the importance of sustainability in its ever-evolving architectural landscape. Registrants of the Architect's



BUILDING FOR TOMORROW.

At United Steel Supply, our commitment to the metal roofing industry is second to none because it's the only segment we serve. We're dedicated to championing our industry's recovery — offering nationwide distribution, full slitting capabilities, just-in-time delivery and the highest quality Galvalume®, galvanized and prepainted steel coils in the nation.

The future is bright in our industry and we will be here to grow with you.

To learn more, contact your USS sales representative.

METALCON
'23
BOOTH #
4076



UnitedSteelSupply.com | 512-263-0954



Experience can stop by the pavilion lounge area.

METALCON TRAINING ZONE

New this year and sponsored by Sherwin-Williams, the METALCON Training Zone provides a hands-on demonstration and training area for contractors, remodelers and others who want to sharpen their skills and deliver their best, most efficient and cleanest work when installing various metal roof offerings and systems. Featuring a variety of mock-ups and materials including aluminum, copper, painted steel zinc and even some exotic materials, training will focus on proper detailing and utilization of the right tools (offered in both English and Spanish). See page 6 for more on the METALCON Training Zone.

WOMEN OF METAL CONSTRUCTION!

Also new this year, women of metal construction are welcome to join their peers before the show kicks off on Wednesday for a morning filled with the perfect blend of breakfast, networking and discussion at the ENVY at the Renaissance Hotel. Gather alongside fellow inspiring women and listen and learn from peers who are shaping the industry. “Metal and Mimosas” is sponsored by ATAS International, CIDAN Machinery, MetalCoffeeShop, the MRA (Metal Roofing Alliance) and METALCON.

METL-SPAN LAS VEGAS PLANT TOUR

Metl-Span, a Nucor® company, invites general contractors, installers and architects to an exclusive plant tour at its Las Vegas facility. Learn from this leading North American manufacturer of insulated metal panels (IMP)s just how they are made on Thursday, October 19 from 8:00-10:30 a.m. (transportation provided). This exclusive experience includes breakfast, networking, a plant tour and an education session “Designing with Commercial/Industrial Insulated Metal Wall Panels” presented by industry expert Kira Rogatnik (earn 1 AIA HSW credit). Learn more at metalcon.com/exclusive-plant-tour.

THE IMP ALLIANCE EDUCATION CENTER

The MCA IMP Alliance (leading manufacturers, material suppliers, and resellers) presents a special seminar, “Insulated Metal Panels – Installation and Handling Best Practices,” on best practices and common mistakes made during the unloading, staging and storage of bundles.

NRCA PROCERTIFICATION® DEMO

NRCA’s engaging demo will introduce what metal panel and metal shingle roof system hands-on assessments look like in its NRCA’s national certification initiative, which certifies experienced installers in specific roof system installations. Learn more at nrca.net/procertification/mc.

LEARNING CENTERS

Check out METALCON’s FREE education sessions! These

METALCON

Wednesday, Oct. 18-Friday, Oct. 20
Las Vegas Convention Center • metalcon.com

METALCON is the largest international event in the metal construction and design industry. Established in 1991, it’s the only annual tradeshow and conference devoted exclusively to the application of metal in design and construction. Each year, contractors, architects, developers, owners, installers, fabricators, manufacturers and suppliers from more than 50 countries attend and 200+ leading companies exhibit. Produced by PSMJ Resources, Inc., in partnership with the Metal Construction Association.

60-minute sessions from 11:15 a.m. to 5:00 p.m. on Wednesday and Thursday are organized into three centers on the show floor: Best Practices, Technical Know-How and Sustainability. Attendees can earn up to 12 hours of CEUs. Additionally, METALCON continues to offer in-depth workshops this year on the Tuesday, Wednesday and Thursday of the show to provide cutting-edge education and training, which cannot be found elsewhere. For a small fee, attendees will be armed with new information, fresh ideas and strategic direction to address some of the major issues facing the construction industry today, including:

- Metal Roof Installation Training Certificate Program
- Rollforming for the Metal Construction Industry
- Metal Roofing from A (Aluminum) to Z (Zinc)
- Low Slope Detailing Workshop – Certificate Course
- Mergers & Acquisitions Essentials Workshop
- RaiNA Installer Training for Rainscreen Assemblies

And in the Best Practices Learning Center, a special “State of the Industry” panel presentation led by members of the MCA will take place on Wednesday, October 19 at 3:45 p.m. to discuss current and future opportunities and challenges facing the metal construction industry.

GIVING BACK

Each year, METALCON gives back to the local community where the show takes place. This year, METALCON is partnering with America’s Fund, a non-profit organization dedicated to helping veterans in all branches of the military. The program was created to direct urgently needed resources and financial support to injured and critically ill members of the U.S. Armed Forces along with their families and is a self-funded program of the Semper Fi Fund (metalcon.com/giving-back).

“We look forward to returning to Las Vegas, a great destination for METALCON. We have a lot of hands-on training opportunities, new educational programming and fabulous keynote speakers,” said Judy Geller, METALCON Show Director. “Make sure to stop by The Deck, conveniently located near registration, to meet show management, network or take a break.” **RF**

**FASTENER HEADS
GUARANTEED
NOT TO RED RUST!**

**HEX HEADS
LIFE-TIME
WARRANTY.**



- **EPDM Concealed Washer!**
- **Type-17 Cut Point!**



ZIMAX™
"THE LONGLIFE FASTENER"

- **H-Low™ Threads!**
- **Deep Threads for Max Holding Power!**



**METALCON
'23
BOOTH #
2021**

LAKESIDE™
CONSTRUCTION FASTENERS

FOLLOW US ON

You Tube



To purchase contact us at:

1203 Goldsmith Road, Paragould, AR 72450
870-586-0703 (office) | 870-586-0643 (fax)
800-537-4160 (toll free)

www.lakeside-fasteners.com

2-2023_V29

Portable Roll Forming

From rough beginnings to state-of-the-art

■ From Metal Roofing Magazine

Note from the editor: This article was originally published in a 2003 edition of Metal Roofing Magazine. While roll forming has continued to evolve over the last 20 years, the origins and early improvements and developments are still the root from which contemporary roll forming grew.

The first portable roof panel roll forming machine built in North America was made by a man who had no experience in roll forming and knew nothing about metal roofing.

“Sometimes it’s good if you have no experience,” says Ewald Stellrecht, who now owns ESE Machines, “It gives you the freedom of new ideas. But I really didn’t know a ridge from an eave.”

The year was 1976, in rural Dutch Country Pennsylvania. Stellrecht, a German-trained engineer, owned a metal tool and die shop that made things like fabric coating line accumulators. A local roofer who specialized in metal on barns and farmhouses brought in a small German-made former he’d leased from a contractor in Texas.



“He brought in the machine and wanted me to copy it,” says Stellrecht. “But he also wanted to be able to adjust the width, which was fixed at a metric dimension.” It took Stellrecht five weeks to figure out the machine, which made simple folds for double-lock standing seam, and to replicate the parts and redesign it for variable widths. He figured he’d built his last roof panel machine.

But the roofer was so pleased with it he suggested they go into business together. Stellrecht wasn’t sure, and put a small notice

BELL'S PATENT ROOFING EDGER.

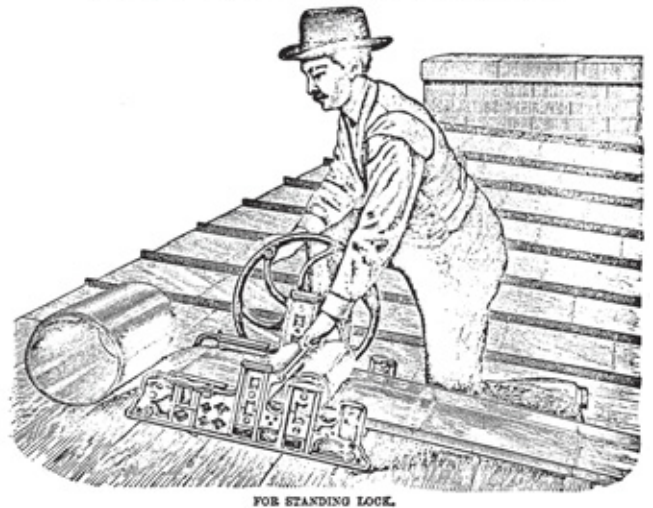

Roll forming machines for roofs have been around since at least the 19th century From Tinsmith's Tools and Machines, published 1888.

IMAGE REPRODUCED WITH PERMISSION FROM DIANA WAITE'S 19TH CENTURY TIN ROOFING (1974).
Below, Willis Stichert Roofing in Chili, Wis., hauled coil to its jobsites in the 1930s about the same way they do today. At left, an Englert machine cranks out rated snap-lock panels indistinguishable from panels made on long factory formers. STICHERT, ENGLERT PHOTOS



in a roofing magazine. He was flooded not just with inquiries but with cash deposits for the next available machine.

Stellrecht revamped his design again to accommodate painted material, and by 1978 had partnered with electronics salesman Phil Altomare to form Roll Former Corporation.

“We thought we’d sell 20 or 30 machines, just to the larger roofers,” says Altomare. “We were just in the right place at the

right time.”

And so an industry was born.

ROLL FORMING ORIGINS

Of course, the roll forming story begins long before this. “It’s basically a thousand-year-old concept,” says Stellrecht. As soon as metal sheets became common in architecture, metalworkers developed machines to fold, bend, and seam them. The roller concept was in use in roofing by the mid-19th century, if not before.

Powered machines to form more intricate shapes in metal were developed at the turn of the century. In 1910, Carl M. Yoder, a draftsman of a Cleveland-area sheet metal company, designed a continuous cold roll forming machine for making mud strips for cars. Two years later, the Trachte Brothers Co. built a roll forming machine in Watertown, Wis., to make corrugated water tanks for livestock. (Yoder Manufacturing, now part of Formtek, continues to fabricate metals for the automotive and other industries, while Trachte now specializes in mini-storage facilities.)

By the 1960s, companies like Butler and Wheeling Corrugating were running huge roll formers that produced structural standing seam and wide, ribbed through-fastened panel for residential and metal and post-frame buildings. These were long, heavy machines with dozens of roller sets, which allowed accurate forming at high line speeds.

The advantages of forming on site occurred to gutter installers long before roofers, and the movement to portable roll forming began with gutter machines. In 1957 Art Knudson made the first jobsite “seamless” gutter machine in a garage in Cedar Falls, Iowa. After several years he moved to the larger market of Colorado, and in 1961 Knudson and son Gary began making Watertite brand gutter machines in Lakewood, Colo. Knudson and other gutter machine makers thrived and even branched out into arch building machines, but didn’t enter the roof panel market until the early 1980s.



IMPROVEMENTS

Stellrecht’s machine was really a labor-saving device for roofers installing traditional double-lock standing seam, formed usually with hand tools such as tongs and crimpers or on shop brakes. “Ewald would travel around New England, especially Vermont, towing a machine. He’d drive up to sites with these traditional roofers and sell them the machine on the spot,” says Engler’s Kevin Corcoran. Since painted material usually came only in sheet form, the appeal wasn’t a matter of eliminating end laps.

The machine was primitive by today’s standards. Panels had to be cut off at the exit end with hand shears, or a saw. “Sometimes they’d cut the sides before the metal went into the machine,” says Roll Former’s Bob Schultz. “That way at least the legs would be cut already.”

Roll Former eventually partnered with the Ball Metal company, which introduced the tricky Micro-Zinc material without sufficient training in installation techniques, leading to that company’s exit from the roofing business. Meanwhile, Stellrecht left Roll Former and decided to build another forming machine from scratch, under the name ESE Machines. By the early 1980s he began producing machine with several important improvements.

The original Roll Former machine was short, about 4 feet long. Stellrecht stretched the machine to 10 feet, adding more forming stations to put less stress on the metal. He then partnered with



Draco to mount an exit-end power shear on the machine. “We took the machine to shows in Europe like Dach & Wand,” says Stellrecht. “The Germans were more advance than us, but only in unpainted material. The shear was a big step, though. When we showed it off, the other guys stopped using their noisy saws.”

Stellrecht also built a decoiler with an expandable arbor for the new ESE machine. “People had been using two tires, deflating and inflating it to hold different size coils in place. It didn’t work well.”

The next improvement came from another engineer. Ron Shell, now with New Tech, was working at Watertite when he got the idea for a machine with separate drive and forming rollers. Until then, metal was pulled through the machine by the forming rollers themselves; for some profiles, the added

Closer Look))

stress on the metal can lead to oil canning. The concept also allowed for different gauges to roll more easily through the machine.

Shell built 10 gutter machines with the new feature, but they didn't catch on — except with Stellrecht, who had Shell build independent drive machines for him and adapted the mechanism for his own. Nowadays most machines rolling profiles that benefit from separate drives have incorporated the technology.

STRUCTURAL MACHINES

Knudson built a few roof panel machines on request during the 1970s, but its gutter business was booming and the company was busy with an arch building machine, the K-Span. Only in 1982 did the company truly enter the metal roofing market, with its P-2401. But the machine had little in common with the Stellrecht's machine. It was much longer, heavier, and rolled a high-legged structural panel that could span 4 feet. The machine, in other words, wasn't a labor-saving device for architectural roofers; it was challenging the metal building panel factory machines.

Knudson followed up with the KR and VP lines, which have

become mainstays of the structural roofing market.

Over the years, dozens of engineers and other employees now in the forming industry got their start at Knudson, some of whom left to found or join related or competing companies such as Zimmerman, Jobsite, and Weather Guard.

When Watertite went bankrupt, Shell took his independent drive idea to a new company, New Tech, founded in 1990 with Larry Coban.

VARIABLE MACHINES

In the late 1980s Roll Former lengthened and improved its machines hydraulic shears and more forming stations, and in 1991 introduced what the company believes was the first machine designed to be changed out to not just widths or leg height, but different panel profiles entirely. The VS-150 could in fact roll seven different types of roofing, including double lock, snap lock, and batten pans.

The industry soon followed suit, with New Tech and Knudson both bringing multi-profile machines to market in the early 1990s. Knudson's Variipan machine and New Tech's Multi-Pro Jr. both produced the more architectural snap-seam, nail strip, and mechanically seamed panels.



Custom machines for any profile.

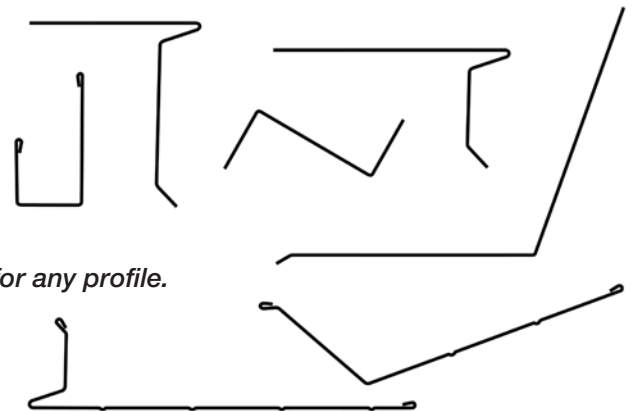

Invest today. Profit tomorrow.

T&H Lemont's DP series roll forming machines are designed for efficiency and built to last. This series isn't burdened with features you don't need and has everything you do. These are robust, high-volume machines that will produce shift after shift, day after day, year after year. Regardless of what you need to make, the DP series from T&H Lemont delivers.



T&H LEMONT

An Inductotherm Group Company

T&H Lemont Inc. • 5118 Dansher Road • Countryside, Illinois, USA • +708-482-1800 • thlemont.com

Along with machines came a maturation in the supply of painted coil. Early on the Kynar-coated coil market was set up for factory quantities, and it could be difficult to buy less than 50,000 lb. master coils. Some roofers used sheet stock; others used coils of galvanized or cheap polyester painted galvanized. As small-scale roll forming grew, companies began to specialize in supplying contractor-sized coils in top-quality Kynar finishes.

Portable makers could now lay claim to numerous benefits: longer unbroken panels, which reduces problematic end laps; lower delivery costs, less packaging, and fewer banged-up panels; and fewer jobsite storage problems. The practice of lifting machines by crane to roof height and rolling panels onto rooftops solidified the idea that jobsite roll formers were the most efficient method of roofing large projects.

The portable market was taking off, but not without opposition. Factory producers claimed that site-produced panels were inferior, were not backed by watertight warranties or technical support, and that unscrupulous contractors could use inferior coil or poor installation techniques. The very versatility of some machines led to the suggestion that a careless contractor could produce shoddy, badly formed panels.

The Berridge Company decided to meet the objections



head-on. Starting in 1984 with the SS-14, the company came out with a series of a dedicated, factory-set width and profile. The company insisted its machine owner use coil coated by the company, and set up a licensee certification program with extensive training and technical support. The company also offered watertight warranties.

CONCRETE WEDGE ANCHORS

Drop-In Anchors

Also known as stud anchors or concrete bolts, wedge anchors offer a strong, durable, and permanent solution for securing materials and equipment to solid concrete surfaces.

Perfect for securing racking in a warehouse, equipment in a manufacturing facility and aluminum carport structures to a concrete slab.



1.800.558.5895
eastcoastfast.com

Closer Look))



In short, the company did everything possible to assuage the fears of architects and specifiers about site-formed metal roofing. “We still see that in the specs, “No site formed panels,” but we just have an engineer contact the parties and they usually set the record straight.”

In whole or part, others in the industry have followed suit. Englert began distributing Knudson gutter machines in 1969, and picked up the Knudson roof panel machine in the early 1980s. The company also became a regional distributor for Roll

Former, ESE, and later New Tech, eventually private-labeling some machines built by these companies to its specifications.

In 1987, noting the difficulty many contractors had getting quality Kynar coil, Englert built a coil-coating facility. Soon it was offering many of the same services as Berridge: coil, clips, engineering support, training, and weathertight warranties. It too now caters extensively to architects.

Although many machines can run several very different profiles, the time necessary to change over is hotly debated. Some machines may take several hours, others a half hour, and proponents of one system will insist another machine’s times are far greater than stated.

In the late 1990s, a late entry in the field grabbed the title for fastest change-over time with little controversy. The German Schleich company, whose machines had long been imported in small numbers, found an aggressive company to market its Quadro machine in MetalForming, Inc. The Quadro uses forming rollers that are mounted on a unique cassette system, so changing profiles is accomplished in seconds by simply lifting out an entire set of rollers and inserting another set (usually with a forklift — it’s a whole lot of steel).

The system doesn’t come cheap, but the Quadro is therefore

Celebrating

**YOUR ONE-STOP SHOP
FOR ALL YOUR
ROOFING &
BUILDING NEEDS**

DEALER/INSTALLER OF:

7716 N. 900 E.
Montgomery, IN 47558

**TRUSSES | LUMBER
WINDOWS | DOORS
LAMINATED COLUMNS
STANDING SEAM METAL
METAL ROOFING &
SIDING PANELS
METAL TRIMS &
COMPONENTS
STONE COATED
STEEL SHINGLES
COMPLETE POST-FRAME
KITS W/ DELIVERY
& MUCH MORE!**

(800) 264-5013

WWW.GRABERPOST.COM

well-suited to the traveling cut-and-drop contractor, who must be ready to roll a wide range of profiles with a single machine. MetalForming has also mounted an aggressive effort to secure wind-uplift engineering on its profiles.

By now, all the structural panel machine makers — Berridge, Knudson, New Tech, Zimmerman — have extensive testing on their machines' panels, and all the companies offer technical support and training. The quality wars between factory and jobsite producers are basically over; most factory-based formers know that jobsite machine can, and usually do, make panels that are indistinguishable from factory-produced ones. Specifications with the phrase "NOTE: Jobsite roll-forming not permitted" rarely crop up. "I've seen some strange things," says Corcoran. "Like 'panels shall be formed by machines bolted to the floor.' It's silly. But you really don't see it much anymore."

But that hasn't ended all the arguments. Factory producers still insist that their products carry better warranties; a jobsite forming contractor essentially becomes the panel's manufacturer, and contractors are often not in business longer than a warranty. They can also say that contractors aren't always as good as their machines, and that individual contractors don't always properly match site-formed panels with the correct clips,

fasteners, and details to make a complete engineered system. But the portable industry has largely shut down these arguments.

Several factory producers, in fact, are buying custom-made portables to site-form when the situation calls for it — such as panels longer than 50 feet, which are difficult to transport. And many portable owners are setting the machines up in shops to roll in controlled conditions. "We started out as a jobsite contractor," says Steyer, "but we found it was sometimes less effort to make it here and haul it." Now he'll decide whether to site-form depending on distance, weather, and other factors.

Now that the machines have been around for a quarter century, is the market saturated yet? Englert's Corcoran sees a bigger market in full-service roofing companies buying machines. "Architects want a single source for the whole roof, so the flat roofing company ends up being responsible for the mansard too."

And there are still people finding out about roll formers. "We had a guy who bought a machine just a few years ago," says Roll Former's Schultz. "He put metal mostly on barns and rural houses, and he'd welded some angle irons together, and would put a vice grip on the metal, and pull it through the irons with a tractor. He saw our machine and was just amazed." **RF**

THE BRADBURY GROUP

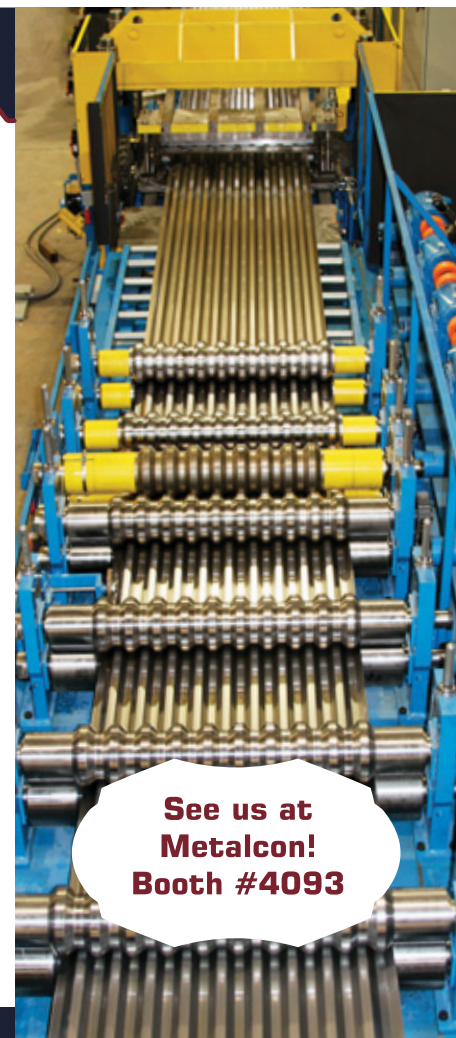

Roof & Wall Panel Roll Forming Lines | Cee & Zee Purlin Roll Forming Lines
 Steel Framing Roll Forming Lines | Insulated Metal Panel Production Lines
 Hydraulic Trim Folders | Trim Roll Formers | Gutter & Downspout Machines
 Metal Shingle Production Lines | CTL / Slit Recoiling Lines
 Retrofits & Rebuilds | Controls | Operator / Maintenance Training

We are a North American Distributor of the Biegemaster X-Bend folder. Bradbury provides technical support, operator training, and spare parts inventory.

bradburygroup.com +1.620.345.6394

**See us at
 Metalcon!
 Booth #4093**

MALCO PRODUCTS WELCOMES TALBOT AS VICE PRESIDENT OF MARKETING

Malco Products has announced that Rebecca Talbot has joined the company as its new vice president of marketing.

As leader of Malco's marketing team, Talbot will oversee, develop, and implement Malco's marketing strategy and efforts to increase brand and market position in order to achieve short- and long-term organizational goals. Talbot comes to Malco with a broad base of marketing accomplishments and professional experience, including positions at DeepRoot Green Infrastructure, Resideo (Honeywell)



Rebecca Talbot

and Lakeland Companies. She holds a bachelor's degree from Metro State University and a Master of Business Administration degree from Georgia Southwestern State University.

Talbot will succeed Nancy Gunnerson, Malco's director of marketing, who recently retired after a 34-year career with Malco. During Gunnerson's time at Malco, she oversaw several innovative programs, including a new e-commerce tool, customer loyalty program and influencer relations campaigns, that contributed to the company's current record-breaking growth. She was also recognized by Twin Cities Business Magazine as a Notable Woman in Manufacturing in 2021.

TFC ACQUIRES PORTION OF CONNECTIVE SYSTEMS & SUPPLY INC.

Triangle Fastener Corporation (TFC) has finalized an acquisition agreement

with Connective Systems & Supply, Inc. (CSS). In particular, TFC has acquired the segment of CSS's business primarily focused on fasteners for roofing, metal building, and mechanical contractors in and around Denver, Colorado.

CSS has been a leading provider of fasteners and products to construction industry professionals since its founding in 1985. This segment of its business is supported by approximately 20 employees in two locations who achieved 15 million in sales in 2022.

The acquisition of CSS aligns with TFC's plans for long-term business growth by developing branch locations in the western United States and expanding its catalog of proprietary TFC-branded products.

In addition to the pending opening of a location in San Antonio, Texas, the integration of CSS assets will bring TFC to a total of 27 US locations, and a marked

STAR 1
PRODUCTS LLC

SOLUTIONS FOR THE ROLLFORMING INDUSTRY



FELT APPLICATOR



ADJUSTABLE WIDE FORKS



COIL TIPPER



COIL RACKS

Bringing innovative solutions to the rollforming industry with superior quality and unparalleled efficiency.

Call for a **FREE** consultation on streamlining your rollforming processes
TOLL FREE PHONE: 88896-STAR1 PHONE 231-825-0163 FAX 231-825-0164

increase in its presence in the central and western United States.

RIVAL HOLDINGS LAUNCHES OPERATIONS

New investment company Rival Holdings launched operations Aug. 1, with a vision to actively transform the real estate, construction and building industry.



Brad Crawford

Rival brings together Ambassador Supply and VIA Developments under one umbrella, while also seeking new investment opportunities. The company will have a strong focus on mergers and acquisitions, real estate acquisition and development, and innovative technologies. As the parent company for Ambassador Supply and VIA, Rival

operates 16 companies in 10 states, with over 800 employees, a real estate portfolio value of \$200 million, and 2 million square feet under management.

Rival CEO Brad Crawford explained the idea behind the creation of the venture company, saying, “As our industry grows and evolves, it is critical that we focus on technology, innovation and disruption. Rival is a company that will work to catalyze innovation and growth, through a holistic view of the real estate and construction industry, and a willingness to take risks and explore possibilities.”

Because VIA and Ambassador Supply have reached a growth point through their holdings, increased services, and view of the industry, leadership decided to consolidate their efforts and focus into a parent company, while allowing them to operate independently.

Ambassador Supply is an investment

and management company operating across rural, residential, and commercial verticals, focusing on manufactured building products, post-frame building solutions, and building materials.

Commercial real estate development and management firm VIA Developments is dedicated to creating a positive and lasting impact on people, businesses, and communities. VIA’s vision is to achieve long-term capital growth and wealth preservation through diverse real estate activities, including investment, development, management, and ownership.





Rival will look for companies demonstrating high-care, high-trust, and high-performance characteristics with strong next-generation leadership and a competitive mentality. The company will apply these principles to its own operations, as well as the companies in its portfolio. **RF**



ASC MACHINE TOOLS, INC.

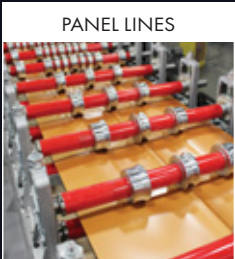
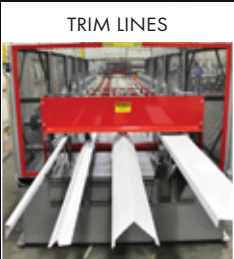
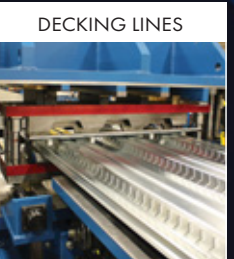
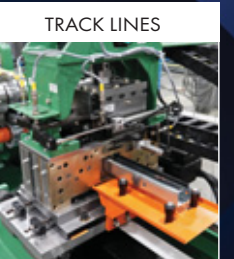
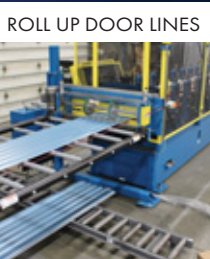

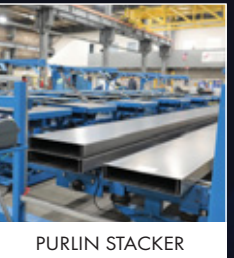
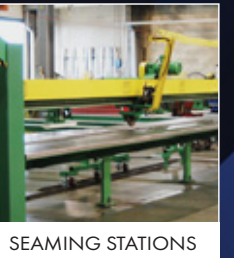
PREMIUM QUALITY ROLLFORMING MACHINERY - MADE IN THE USA SINCE 1949

 <p>PANEL LINES</p>	 <p>TRIM LINES</p>	 <p>DECKING LINES</p>	 <p>TRACK LINES</p>	 <p>ROLL UP DOOR LINES</p>
 <p>CHANNEL LINES</p>	 <p>CZ PURLIN LINES</p>	 <p>PURLIN STACKER</p>	 <p>SEAMING STATIONS</p>	 <p>ROLL-UP STATIONS</p>

METALCON
OCT 18 -20, 2023, LAS VEGAS, NV
BOOTH 6019

THE BUILDER SHOW
JAN 24&25, 2024
KNOXVILLE, TN
BOOTH 317

VISIT US AT OUR
UPCOMING TRADESHOWS

INTERNATIONAL ROOFING EXPO
FEB 6-8, 2024
LAS VEGAS, NV
BOOTH 8435

NFBA NATIONAL FRAME BUILDING ASSOCIATION
MARCH 6-8, 2024
DES MOINES, IA
BOOTH 521

SHOWTIME

THE \$50
PRE-REGISTRATION
FEE FOR ADMISSION
COVERS BOTH
DAYS AS WELL AS
THE EDUCATIONAL
SEMINARS.

Punch Your TicketS to our next EVENTS!

FROM THE
PUBLISHER
OF GARAGE,
SHED &
CARPORT
MAGAZINE



2024

GARAGE • SHED • CARPORT
**BUILDER
SHOW**

JANUARY 24-25, 2024

Knoxville Convention Center, Knoxville, TN
garageshedcarportshow.com

ADMIT 1

FROM THE
PUBLISHER
OF FRAME
BUILDING
NEWS



2024

**POST-FRAME
BUILDER SHOW**

JUNE 19-20, 2024

Branson Convention Center, Branson, MO
postframebuildershow.com

ADMIT 1

For More Information Contact Missy Beyer:
missy@shieldwallmedia.com • PH 920-216-3007

Shear Perfection

How quality metal cutting snips make the job easier, safer, and top-notch

■ By Tom Batho, New Product Development Manager, Malco Products, SBC

Back in the early 1990s, a home improvement editor at Popular Mechanics recommended that folks keep a snips-type metal cutter in their home tool boxes just for the “shear pleasure of it.” While we still agree with that advice for home repairs, snips are a must-have component of toolboxes for metal roofing professionals because of their function, form and fit.

FUNCTION

Contractors, builders and roofers want tools that make their work more efficient in a variety of ways — one-and-done trips to the job site, quality work at all times with no reworking, and no material waste. The nature of the metal roofing business means that there’s an interest in specialty tools, especially when it comes to the best tool for the application at hand. A quality pair of snips are considered a staple because they allow trade professionals to make the cleanest, most efficient cuts possible across a wide range of materials.

Because metal roofing pros rely on snips to effectively and efficiently get the job done, there are now a variety of snips available that include different features depending on how they will be used on the jobsite. Lightweight metal cutting snips provide a long cut, are lightweight and good for cutting lighter gauges of metal along with other materials. Builders and roofers needing to make long cuts tend to prefer the lightweight option. Additionally, these snips are meant to be used over and over again so they are extremely durable, and many offer replacement blades so that you can get the most out of your tool.

The top line versions of lightweight metal cutting snips ensure that metal roofing professionals can make cuts that are long and tight and provide straight and left-curve cuts of the highest quality across various materials, including sheet metal, metal roofing, aluminum, stainless steel, steel siding and vinyl.

Aviation snips provide high quality, short cuts on heavier sheet metal gauges that require more strokes and cycles compared to a lightweight metal cutting snips. Models with an offset design are popular as they improve material flow and are safer because the users hand does not meet up with the material as easily as with a straight snip. These tools have industry-standard color coding handles for quick identification of the type of snips. Aviation snips also have a spring design which allows for the snips to “self-open.” Mini-aviation models are another great option. At only a little over 7” in length, this version perfectly fits in tool belts,



“Left” snips by Malco Products, SBC. Note the tight radius of the cut.
PHOTO COURTESY OF MALCO TOOLS.

allows for access in tight spaces, and is a good fit for any small, unplanned cutting needs.

While lightweight and aviation snips are the most common, specialty versions such as heavy-duty forged steel snips — regular pattern snips for straight and wide curves and duckbill snips to cut tighter circles — provide trade professionals powerful cuts with great maneuverability. In addition, vertical snips have an advantage in tight locations, making it easy to get a quality cut with an angled snip.

Metal roofing professionals also might want to consider the benefits of using powered tools in certain situations. A powered solution is a great option when making long cuts since it reduces fatigue and improves ergonomics. Power assisted shear solutions are flexible, allowing for a quick interchange between a shear and drill or driver.

Most trade professionals are likely to include both lightweight

Product Feature))

snips and aviation snips in their tool kits, using the lightweight version to work through long cuts and the aviation snips for shorter cuts, where maneuverability is needed, and heavier gauge steel is used.

FORM

There are specific traits trade professionals should look for when purchasing high-quality snips. Prior to testing out the snip, it's good practice to inspect the tool making sure that the overall fit and finish of the components (handles, grips, latch, and blades/jaws) is of high quality, the action of the snip is smooth, and it's a comfortable fit in the hand during the range of motion. Also make sure to review the safety warnings, confirm the tool is made using high quality steel, and verify the cutting capacity of the tool prior to use.

Once you've inspected the tool, it's time to test it out. Exceptional products should have an ease of cut and no pinch points. They shouldn't tear or catch on the metal that's being cut. The ability to cut to the tip of the blades in one motion and a smooth, clean cut with no burrs are the hallmarks of a quality tool. Make sure you get a feel for the control of the cutting and

determine if there's a preference of design, for example function of the latch or serrated cutting edge. By cycling the snips, you can test out if there's a consistent, smooth scissors action and try out maneuverability.

The key to a good user experience with snips is to follow the experts' advice for using them safely and efficiently. Trade pros should always follow the manufacturer's safety warnings. It's also important to understand the manufacturer's warranty. A company that backs up their tools by stating the full warranty for the life of a product when used in normal conditions equates to not only quality but safety.

Professionals should use the tool as intended and be aware of its capacities. Tools not used as intended may lead to injuries, inefficiency and void the warranty. Finally, make sure to pick the right snip for the job. By selecting the right tool, users will obtain the best results in an efficient timeframe, getting them on to the next jobsite in a timely manner.

FIT

You can spend a fair amount of time researching, reviewing and cutting metal before purchasing a new pair of snips, but it's

THE BEST METAL ROOFING BENDERS.



Malco[®]

**Malco's Metal Benders.
The latest in a long line
of #DamnGoodTools.™**

Metal Benders by Malco will quickly become your jobsite go-to. Durable, precise, and versatile, Malco's modular metal benders are built for tough bending brilliance on metal roofing. Customizable to each jobsite, your one or two station set-ups allow you to get the job done quickly and efficiently.

METALCON

SEPTEMBER 18-20, 2023 / LAS VEGAS CONVENTION CENTER

VISIT US AT BOOTH #1000



imperative that the tool has a good fit and a feeling of quality in your hand. With a high-quality pair of snips, building pros can reduce the total number of cuts needed and decrease the total number of repetitive motions.

Overall comfort is a personal preference for each user, for example some professionals like aviation snips with a traditional handle design while others want an ergonomically symmetrical design. Whatever the preference, design for efficiency and comfort in the working environment, should be on your checklist when thinking about the fit of the snips. Personal comfort, accompanied by the weight of the snips, material flow, smoothness and finding a suitable solution for the needed application all fall under the ergonomic umbrella of high-quality tools.

At Malco, aviation, lightweight and

steel snips are some of the most popular, long-standing product lines. Malco continues to build on this legacy of excellence by bringing high-quality, new versions to the trades. Innovative snip and shearing

tools have always been about making the job easier and safer for trade professionals. The top products on the market do this while consistently evolving to meet the future needs of the industry. **RF**

BECK Automation Integrate and Optimize Your Business with Beck Automation's Connex Software

- Connect and synchronize your roll forming machines, ERP software, and design software with ease.
- Streamline your production processes and eliminate manual data entry.
- Achieve greater efficiency, productivity, and accuracy throughout your operations.

sales@beckautomation.com / 314-576-9736

ADVANCED ARCHITECTURAL

SHEET METAL & SUPPLY

We service your needs with consistent quality, workmanship and knowledge

- It's part of the reason customers come back to us time after time.
- Maximize your profits by decreasing your inventory. Reduce man hours - let us fabricate, you install.
- 98% of our American-made products are made-to-order and are manufactured inhouse. Our products are made from domestic metal and custom crafted to your specifications.

Contact us today to see how we can streamline your process and maximize your profits!

(231) 861-0050 | info@advarchsm.com | www.advarchsm.com

Up From the Ashes

Equipment Restored After Devastating Fire

■ By Karen Knapstein

When disaster strikes your roll forming shop, all may not be lost. There are places you can turn to rebuild. Although losses may be catastrophic, it may not be necessary to start over.

For example, in February 2023, Sunset Metals of Ebensburg, Pennsylvania, suffered a devastating fire, which destroyed most of the company's building. A single structure housed the metal shop, the inventory, and the office. Therefore, the equipment, the coil stock, the inventory, and even the company records were consumed in the fire.

The fire turned all the stock and inventory into scrap metal.
PHOTO COURTESY OF SUNSET METALS



DISASTER STRIKES

Owner John Hershberger explains the metal-forming equipment in the shop was powered with a diesel generator housed in an enclosed lean-to at the back of the building. "I had just got done rolling a metal order at 3 p.m. and hadn't noticed anything out of the normal." The guys noticed smoke coming out of the motor room; the fire department was called right away. A bearing at the wall

overheated and caused a fire. The guys grabbed fire extinguishers and thought they had the fire out. "But the foam insulation board inside the wall, which was covered with metal inside and



Coil upender, before and after restoration. EQUIPMENT PHOTOS COURTESY OF ACU-FORM

out, caught fire and they couldn't get to the blaze to put it out.

"The fire department was here within 10 minutes, and about 5 minutes later the ceiling was falling in," John recalls. "The wall cavity acted like a chimney, and there was a pretty strong south wind that day. The fire grew and engulfed the trusses; since all of the business departments were under a single roof, everything was destroyed."

Only 25 minutes had lapsed between the first notice of fire until the roof fell in. There were seven fire departments on scene and they couldn't get the fire under control. By 9:30 p.m. it was all over.

The losses included the company's 60' x 200' metal shop and about half of the 52' x 126' addition that was nearly finished. In one afternoon, a bustling business



Ag panel machine damaged during the fire, before and after restoration.



was reduced to mostly scrap. "It was devastating to stand there and see everything that we had worked for the last 9 1/2 years was gone," John recollects. The

Panel Rollformers
Titan, Signature & Patriot

Trim Rollformers
Single & Multi Profiles

Slitting Lines
Stand Alone, Cut to Length, & Slit to Recoil

Decoilers, Upenders, Shears
and much more!

The Affordable Rollforming Equipment Manufacturer

888.284.6794 | www.mrsrollform.com
info@mrsrollform.com
 4511 N Freya St. | Spokane, WA 99217

30 A 30 YEAR HERITAGE METAL OF HONOR 2017 6x WINNER 2023 METAL ROLLING TOP 10 PRODUCT METALCON '23 BOOTH # 5057

MRS
METAL ROLLFORMING SYSTEMS

f in [QR Code]



Before the restoration, the machines looked like they would be recycled as scrap metal. PHOTOS COURTESY OF ACU-FORM

fire resulted in more than 300 tons of scrap metal. The cleanup began immediately after a restless night. “The equipment was all pulled out and I thought that it was probably not worth saving,” he says. Then John called Wayne Troyer at Acu-form, who sent two technicians to evaluate the situation.

After the technicians sent Wayne pictures, it was decided to ship the equipment back to the company to see what could be done to salvage it. So the damaged machines were loaded onto semi-trucks and trailers from a local sawmill and hauled some 240 miles back to the Acu-Form facility in Millersburg, Ohio.

Standing Seam Solutions

Customized Service & Equipment

YOUR WORK. YOUR WAY.

- NTM Roll Forming Machines
- Complete Equipment Packages
- Problem Solving Customer Service
- Real World Installer Experience



For Standing Seam Solutions
CALL 260.463.4010





STANDING SEAM summit

An Educational Event
for the Portable Rollforming Industry

TWO DAY EVENT
JAN 25-26, 2024

THURSDAY
Local Business & Manufacturing Tour

FRIDAY
Engaging Speakers & Informational Seminars

HOSTED BY
Formwright 

LOCATION: LAGRANGE, IN

Call For More Information
260.463.4010



REFURBISHING EQUIPMENT

Wayne felt he needed to do whatever he could to help — and quickly. He says to replace all the burned equipment with new machines, “it would cost at least \$500,000. And the downtime is costly because he wouldn’t have income over however many months it would take to get those machines.”

In all, four loads of scorched equipment — 12 pieces in all — arrived in Millersburg beginning in early March. Once the equipment arrived, Acu-Form recruited outside help to take

it apart. “We got contractors, roofers, and construction workers who didn’t have work when it was snowy,” Wayne explains. “They helped take the machines apart. We salvaged the main frames, most of the guards, and the dies and the shafts.”

What they found was there was no warping or metal

disfigurement. “The frames that we build and the material we use are heavy enough that it wasn’t warped so we couldn’t use it,” Wayne explains. “Once the pieces were taken apart and cleaned up, we added the new parts that were needed and rebuilt them, the same as we would build any other machine.”

All the frames were sandblasted and the dies and shafts were all cleaned by hand, so it took much more time and labor to refurbish the burned machines than it would have taken to build new machines. “We put almost 700 man hours into the machines to get them ready to ship again,” explains Wayne. “Building new machines would have been less than half that time. We wanted to make sure everything was right when we got it done so we wouldn’t have to take them apart again. We wanted to make sure we did it right the first time.”

The machines that were restored at a fraction of the price that it would have been to buy new include: an ag panel with post-cut shear; two uncoilers; a coil upender; a hemmer; a snow guard machine; a ridge cap machine; a J channel machine; a large corner machine; a mini corner machine; a residential corner machine; and a perforator.

“We still have a slit line that we have to do,” says Wayne, “but [John’s] got a slitter and shear that he’s using right now that he had before, so he said whenever we can get to it it will be fine.”

MAKE THE SWITCH TO ACECLAMP®





PRE-ASSEMBLED • FASTEST INSTALLING

Patented non-penetrating sliding pin clamps secure *without* the rotation, friction and heat.



SNOW RETENTION | SOLAR

ORDERS: 860-773-4144

www.AceClamp.com



Manufacturer Of Metal Roll Forming Equipment

- Ag Panels
 - Ridge Caps
 - Hemmers
 - Slitters
 - Uncoilers
 - Corners
 - J Channels
 - Rat Guards
 - Wrappers
 - Slit Lines
 - Roll & Tables
 - Post Cut Shears
- Custom Options Available



Commercial and residential construction use with D2 tool steel as a standard for our tooling.

Electric, Hydraulic or Mechanical Options

10550 TWP Road 262 Millersburg, OH 44654 P: (330) 674-4403 F: (330) 674-4035 wayne@acuform.com acuformequipment.com

Cover Story))

In all, it took just 2 1/2 months to restore a dozen machines and return them to Sunset Metals.

BUILDING ANEW

With a lot of help from the community, the burned-out building was replaced with three separate buildings: two manufacturing buildings and an office building. [Two of which had roofs already by February 20.] John decided to “not build back and have everything in the same building. So that if we ever have a fire again it will be contained to one building, and we won’t lose everything.” As an added precaution, the buildings are situated 80’ apart.

Sunset Metals has been up and running since May 14. Considering the extensive losses, it’s amazing the business was built back and running in three months. “Our contractors are all coming back, and we are as busy as we usually are



Operations were divided into separate buildings spaced 80’ apart to avoid the chance of another total loss in the event that fire breaks out again. PHOTO COURTESY OF SUNSET METALS

at this time of year,” John says.

John is impressed by what Acu-Form was able to achieve. They “did a magnificent job refurbishing all of the equipment and it looks brand new and works like brand new. Acu-Form and their employees deserve a big thank you from us. This was all done in a short and timely manner; we cannot be thankful enough for all that they have done for us.”

He further expresses his gratitude to the community and his employees:

“We want to take this opportunity to thank our employees who worked very hard with everything from cleanup to rebuilding to working on the equipment and setting up the equipment. We can never thank them enough! We would also like to thank the community for pulling together and helping us in these difficult times. Also, Wayne with Acu-Form and all they did for a magnificent job they all deserve a big Thank you! (All The Glory To God.)” RF

VISIT BOOTH 6067

Let us be Your Warehouse!

We stock it so you don't have to!



Red Dot Products, LLC

833-473-3368

465 N Reading Rd,
Ephrata, PA 17522

Fax: (717) 740-6644

RedDotProducts.com



We ADD the VALUE to the METAL



- Full Panel Systems
- Single & Multi-profile Trim Lines
- Precut Lines with or without Slitter
- Uncoiler (all styles) & Material Stackers
- Shears (precut, postcut, flying, etc.)
- In-Line Punching & Notching Dies
- Machines Custom Designed & Fabricated to Customer Specifications



Phone: 620-382-3751

Web: www.marionmanufacturing.com

E-mail: sales@marionmanufacturing.com

201 S. Coble St., Marion, KS 66861-1137

Form Your Future with Marion Manufacturing

MetalForming

Open to New Ideas, New Technology...Opportunities Abound!

■ By Linda Schmid

A COMPANY IS BORN

Last year MetalForming celebrated its 25th year in business distributing some of the industry's highest quality roll-forming machinery. That is quite a win for a company that got its start with one guy in a garage.

Geoff Stone was the man in that garage. He worked with German manufacturer RAS to distribute metal folding machines in North America. He believed the automated roll-forming machines being produced in Europe had no match in America. This visionary businessman saw this as an opportunity and he shipped some machinery to a trade show in Las Vegas to test the waters. It went well and Stone founded MetalForming.

The company began as the North American distributor for Jorns (CNC Metal Machinery) Long Folders. The next year they added Schechtel machines to their lineup. More top-tier brands followed suit after that. Every new line brought growth.

Before Geoff Stone came along, contractors were in a difficult position, according to Ken McLauchlan, Vice President of Architectural Sales. They could order from one or two sources which sometimes meant jobs were delayed as they were shipped long distance to job sites, or they could try to get by with the more common, domestically available machines, which were largely manual and time-consuming. However, as is still true



The MetalForming Team

today, there wasn't enough skilled labor to go around, so the automated machinery was preferred, allowing builders to create panels in volume and take control of their own supply. For that reason, many contractors chose a third option and partnered with MetalForming .

COMPANY GROWTH

As a purveyor of advanced technology looking for ways to improve efficiency and customer service, MetalForming partnered with Microsoft and Georgia Tech. These collaborations led to remote machine diagnostics, mobile

machine programming, computer integrated roof manufacturing, and Vantedgepoint®, which brought automated measurement to their roofing customers.

The company serves roofing and architectural sheet metal contractors, with a focus on sheet metal for moisture protection, roofing, and siding, as well as window companies that make flashing. Their diverse offerings also include markets outside of construction, including sign makers, truck body makers, and industrial fabrication.

Continuous collaboration with customers leads to something new

Business Profile))

always in the works: new products, software updates, safety updates, or new machine profiles. Recently, geometry upgrades were programmed into slitters leading to improved angle capability. McLauchlan's team assists customers in staying abreast of what is new and what will help each company attain success.

Located in Peachtree, Georgia, the company has an extensive market reach throughout the U.S., Canada, the Caribbean, and parts of South America.



MetalForming Headquarters in Peachtree City, Georgia

CHALLENGES

In recent years everyone has faced many of the same challenges, including limited labor and supply chain issues. However, in an exceedingly technologically driven market such as roll-forming equipment, it is especially challenging. Much technology is

dependent on components that come from overseas, McLauchlan says.

“Supply chains are better, but still a problem,” he observed. “New chip facilities are being built, but it’s not enough. They need more people to make components; these plants are

supplying the world and when they get behind, it’s a trickle-down effect.”

On the labor front, the company needs highly skilled employees who can learn the new technology, service the machines and train customers on their new or upgraded equipment. One thing

“STAND ALONE” PERFORATION MACHINE

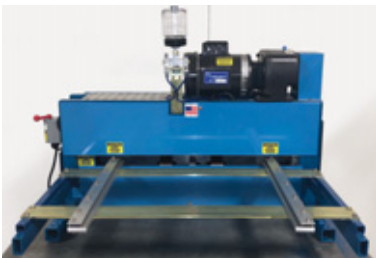

Save time and money using our Stand Alone Perforation Machine.

This sheet fed unit will perforate up to 24” wide material. 26-24 ga. Steel, .032 Aluminum 12-20-oz Cooper. Complete with (2) adjustable perforation dies, this unit is ideal for all of your customized soffit and ridge cap venting profiles.

**CALL US TODAY AT
215-997-2511!**

ROLLFORMER
CHANGING THE SHAPE OF METAL

140 Independence Lane • Chalfont, PA 18914
215-997-2511 • Fax 215-997-5544
www.rollformerllc.com

STATEMENT OF OWNERSHIP, MANAGEMENT AND CIRCULATION (required by Act of August 12, 1970: Section 3685, Title 39, United States Code). 1. ROLLFORMING. 2. (ISSN: 2639-6742) 3. Filing date: 7/28/23. 4. Issue frequency: February, April, June, August, October, December. 5. Number of issues published annually: 6. 6. The annual subscription price is 19.98. 7. Complete mailing address of known office of publication: Shield Wall Media LLC, 1990 Godfrey Dr., Waupaca, WI 54981. 8. Complete mailing address of headquarters or general business office of publisher: Shield Wall Media LLC, 150 Depot St., Iola, WI 54945. 9. Full names and complete mailing addresses of publisher, editor, and managing editor. Publisher: Gary Reichert, 1990 Godfrey Dr., Waupaca, WI 54981. Editor: Karen Knapstein, 1990 Godfrey Dr., Waupaca, WI 54981. Managing Editor: Gary Reichert, 1990 Godfrey Dr., Waupaca, WI 54981. 10. Owner: Shield Wall Media LLC, Gary Reichert, 150 Depot St., Iola, WI 54945 and My Time Media Americas, 1675 Broadway, 20th Floor, New York, NY 10019. 11. Known bondholders, mortgages, and other security holders owning or holding 1 percent or more of total amount of bonds, mortgages or other securities: None. 12. Tax status: Has Not Changed During Preceding 12 Months. 13. Publisher title: ROLLFORMING. 14. Issue date for circulation data below: July 28, 2023. 15. The extent and nature of circulation: A. Total number of copies printed (Net press run). Average number of copies each issue during preceding 12 months: 0. Actual number of copies of single issue published nearest to filing date: 0. B. Paid/requested circulation. 1. Mailed outside-county paid subscriptions/requested. Average number of copies each issue during the preceding 12 months: 130. Actual number of copies of single issue published nearest to filing date: 144. 2. Mailed in-county paid subscriptions/requested. Average number of copies each issue during the preceding 12 months: 15,600. Actual number of copies of single issue published nearest to filing date: 15,960. 3. Sales through dealers and carriers, street vendors and counter sales. Average number of copies each issue during the preceding 12 months: 0. Actual number of copies of single issue published nearest to filing date: 0. 4. Requested copies distribution through other classes mailed through the USPS. Average number of copies each issue during the preceding 12 months: 0. Actual number of copies of single issue published nearest to filing date: 0. C. Total paid/requested distribution. Average number of copies each issue during preceding 12 months: 15,730. Actual number of copies of single issue published nearest to filing date: 16,104. D. Non-requested distribution (by mail and outside mail). 1. Outside-County Non-requested copies. Average number of copies each issue during the preceding 12 months: 0. Number of copies of single issue published nearest to filing date: 0. 2. In-county non-requested copies. Average number of copies each issue during the preceding 12 months: 0. Number of copies of single issue published nearest to filing date: 0. 3. Non-requested copies mailed at other Classes through the USPS. Average number of copies each issue during preceding 12 months: 20. Number of copies of single issue published nearest to filing date: 20. 4. Non-requested copies distributed outside the mail. Average number of copies each issue during preceding 12 months: 70. Number of copies of single issue published nearest to filing date: 300. E. Total Non-requested distribution. Average number of copies each issue during preceding 12 months: 90. Actual number of copies of single issue published nearest to filing date: 320. F. Total distribution (sum of 15c and 15e). Average number of copies each issue during preceding 12 months: 14,982. Actual number of copies of single issue published nearest to filing date: 15,327. G. Copies not Distributed. Average number of copies each issue during preceding 12 months: 50. Actual number of copies of single issue published nearest to filing date: 25. H. Total (sum of 15f and 15g). Average number of copies each issue during preceding 12 months: 15,032. Actual number of copies of single issue published nearest to filing: 15,352. I. Percent paid. Average percent of copies paid/requested for the preceding 12 months: 99%. Actual percent of copies paid/requested for the preceding 12 months: 99%. 16. Electronic Copy Circulation: A. Paid Electronic Copies. Average number of copies each issue during preceding 12 months: 0. Actual number of copies of single issue published nearest to filing date: 0. B. Total Paid Print Copies (Line 15c) + Paid Electronic Copies (Line 16a). Average number of copies each issue during preceding 12 months: 15,730. Actual number of copies of single issue published nearest to filing date: 18,824. C. Total Print Distribution (Line 15f) + Paid Electronic Copies (Line 16a). Average number of copies each issue during preceding 12 months: 14,982. Actual number of copies of single issue published nearest to filing date: 15,327. D. Percent Paid (Both Print & Electronic Copies) (16b divided by 16c x 100). Average number of copies each issue during preceding 12 months: 0. Actual number of copies of single issue published nearest to filing date: 0. I certify that 50% of all distributed copies (electronic and print) are paid above nominal price. 17. Publication of statement of ownership for a Requester publication will be printed in the October 2023 issue of the publication. 18. Signature and title of editor, publisher, business manager, or owner: Gary Reichert, Publisher. I certify that all information furnished on this form is true and complete. I understand that anyone who furnishes false or misleading information on this form or who omits material or information requested on the form may be subject to criminal sanction and civil actions.

that is certain to help them attract talent is a positive company culture.

CULTURE & MARKETING MATTERS

Perhaps William Drury, President and COO of the company says it best: “Everybody matters.” According to McLauchlan, this means that every single employee touches the customer in some way so everyone should be heard. The company has found that valuing input across the board can lead to an openness that employees find engaging, and it engenders a culture focused on solutions, thereby turning problems into opportunities.

An example of the company’s openness to new ideas is its new marketing plan. Tandi McKissick, Director of Marketing, says that as one of the most recent

recruits, starting in January of this year, she came into a company that had a specific way of marketing, mainly print. However, McKissick’s focus is digital and driven by analytics, which seems like a good fit for the company, considering that the people they are selling to are investing in high-end technology. At the same time, construction tends to be a conservative, traditionally minded industry, and McKissick says that she is continuing to invest in print to ensure that they are not losing opportunities to interact with experienced industry workers, but they are also tapping into the online market using SEO, pay-per-click, social media, and other channels that resonate more with younger workers.

THE COMPANY’S TRAJECTORY



McLauchlan says the focus is on

growth, partnership, and investment — investment in people and in the company. With the reduction in the work force and many people bypassing the trades as an option, further automation seems the most viable pathway with more and more computer-driven solutions implemented in the industry. Collaboration is key, and MetalForming is poised to grow and adapt, leveraging innovative technologies and strategic partnerships to serve its customers in a way that lives up to its slogan: One Partner, Trusted Expert. RF

 For more titles, check out Shield Wall Media online: www.shieldwallmedia.com



Install Your Metal Ridge Vent
FASTER THAN EVER

-  PRE-CUT LENGTHS
-  PRE-PUNCHED FASTENERS
-  PRE-APPLIED BUTYL TAPE

CALL US!
(717) 572-0910



SINGLE SOURCE

PANCLIP

SCAMP



Whether a metal roof is standing seam or exposed fastener, DMI has the high quality products for a successful roof project.

- PANCLIP low-profile Pancake & Wafer Head standing seam roof screws & panel clips for SNAP-LOCK & MECHANICAL LOCK profiles.
- SCAMP 304 SS Cap Type 17 & SD Points for Post-Frame & Steel-Frame metal building applications have a 40 year warranty.
- PANCLIP & SCAMP Fasteners meet Dade County, FL specifications for coastal, high-corrosion applications.
- Accessories such as Pipe Flashings, Butyl Mastic & tube sealants, 304 SS Rivets, solid & vented foam closure strips round out the product line.



Let DMI be the SINGLE SOURCE you can rely on for your next metal roof project.

CALL 855-800-8878
www.directmetalsinc.com

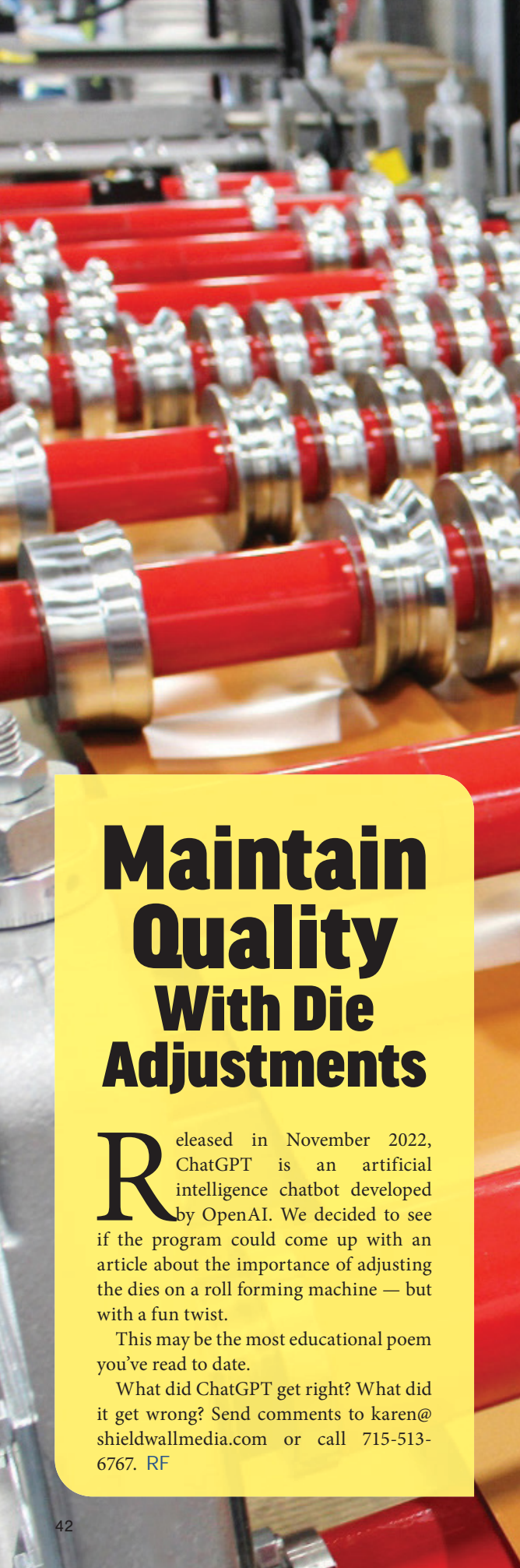

Maintain Quality With Die Adjustments

Released in November 2022, ChatGPT is an artificial intelligence chatbot developed by OpenAI. We decided to see if the program could come up with an article about the importance of adjusting the dies on a roll forming machine — but with a fun twist.

This may be the most educational poem you've read to date.

What did ChatGPT get right? What did it get wrong? Send comments to karen@shieldwallmedia.com or call 715-513-6767. RF

Adjusting the Dies on an Ag Panel Roll Forming Machine

By ChatGPT

*Roll forming is a process that's quite unique
It bends and shapes metal with force and technique*

Rollers and dies work together in sync

To form profiles and shapes that are quite distinct

When it comes to ag panel, a common use

The process is crucial, and you must produce

A product that's straight, uniform, and precise

With no defects or flaws, a true work of art

The dies are the key to a successful run

They shape the metal and make it into one

A perfect ag panel that's strong and true

A product that's worth it, for me and for you

But adjusting the dies is not an easy task

It takes knowledge and skill, and a steady hand to ask

The right questions, and make the right moves

To get the ag panel that's straight and smooth

First, you must start with a good set of dies

That are sharp and true, with no visible lies

Check them for wear and tear, and make sure they're clean

Inspect them closely, for any visible sheen

Next, you'll need to set the right gap

Between the rollers, and the dies that tap

The metal into shape, with force and strength

To create a panel that has the right length

Measure the metal, and adjust the dies

Until you get the right size, with no surprise

Make small changes, and check the product

To ensure that it's good, and you can connect

The final step is to make sure it's straight

That the ag panel has no crooked trait

Adjust the rollers, and check again

Until you get it right, with no visible pain

Roll forming is an art that takes some skill

But with practice and patience, you'll get the thrill

Of making ag panels that are strong and true

And providing a product that's worth it, for me and for you.

In conclusion, adjusting the dies on a roll forming machine for ag panel is a crucial step in the roll forming process. It requires knowledge, skill, and patience to ensure that the product is straight, uniform, and precise. By following the steps outlined above, you can produce ag panels that are of the highest quality, and provide a product that's worth it, for you and your customers.

Golden Rule
FASTENERS

**QUALITY PRODUCTS
COMPETITIVE PRICES
& MOST ORDERS SHIP THE SAME DAY**

- Screws • Closures • Ridge Vent
- Pipe Flashings • Butyl Tape • And much more!

Ph: (334) 283-4030 - FAX (334) 283-4032
info@goldenrulefastenersinc.com - www.goldenrulefastenersinc.com

Aztec Washer Company

MASTER FLASH®
ROOFING • PLUMBING • ELECTRICAL • HV/AC • SOLAR

From the smallest to the **LARGEST**,
the most complete line available.

Pipe Range: Fits: 1/8" to 39-1/2" Pipes
Base Range: 2-1/4" to 44" (1 meter)

1-800-WASHER 5 (927-4375) • Ph: 858-513-4350 • info@aztecwasher.com • www.aztecwasher.com

WE ADD THE VALUE TO THE METAL

MARION MANUFACTURING

- Automation Systems
- Metal Construction Rollformers
- Coil Processing
- Forming & Fabrication
- Recondition Existing Machines

620-382-3751
www.marionmanufacturing.com

METALCON #1023

SAMCO
People. Products. Passion.

Providing Complete Turnkey Roll Forming Solutions for Over 50 Years

1 416 285 0619
www.samco-machinery.com

METALCON #5087

LEVI'S

Snow DEFENDER.

Scan to view our *Snow Defenders!*

Request a Sample!

METALCON #2076

Your Single Source Equipment Provider

- Pre-Cut Rollformers
- Post-Cut Rollformers
- Trim Folders
- Trim Rollformers
- Slit & Recoil Lines
- Controls

THE BRADBURY GROUP

1.620.345.6394
bradburygroup.com

METALCON #4093

DAY STAR™
High Performance Natural Lighting Systems

Let **light** in, naturally.

- ✓ Roof Connection Components Included
- ✓ Even, glare-free light distribution
- ✓ Energy Conservation & Efficiency
- ✓ Trouble-free Installation

GIVE US A CALL TODAY!
866-7-DAYSTAR

I BEAM SLIDING DOORS

MADE IN USA

DOORS THAT WORK!

960 E Cemetery Ave, Chenoa, IL 61726
815-945-3667 • ibeamdoor.com
ibeamdoor@gmail.com



UNITED STEEL SUPPLY

STEEL PRODUCTS FOR THE METAL ROOFING & METAL BUILDING INDUSTRY

Understanding Superior Service

512-263-0954 • unitedsteelsupply.com

METALCON #4076

Productive Trim Solutions



Variobend **SLINET**
USA ASBOMACHINES

Hershey's METAL MEISTER LLC

877-289-3030
info@hersheysmm.com
VariobendUSA.com

METALCON #7116

WRAP THEIR BUILDING UP WITH WARMTH! **NEW!!!**



FAST • EASY • LOW COST

Retrofit Clip

www.retrofitclip.com • retrofitclip@hotmail.com
1-800-431-9661 • Manitoba, Canada

Metal & Vinyl SLITTER

NEW & IMPROVED

JAMESWAY TOOLS

Dealers Wanted!

VINYL SQUARE Valley Square

JTS Sales

9951 Dickey Road
Marysville, Indiana 47141
812-289-1274

SteelGrip SAMM, Inc.
Preventing Injuries and Saving Lives®

SAMM MATS:
Easy to use magnetic grip provides safer footing when working on steel roofing. Get maintenance jobs done faster and easier.



231-944-0109
SteelGripSamm.com

CARPORT FRAMING TUBE MILLS

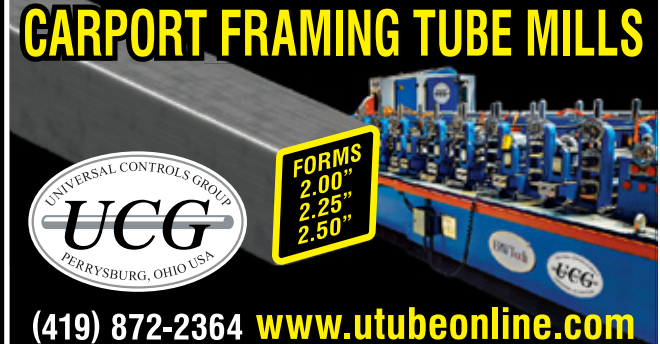

UNIVERSAL CONTROLS GROUP
UCG
PERRYSBURG, OHIO USA

FORMS 2.00" 2.25" 2.50"

(419) 872-2364 www.utubeonline.com

PSI Green Post™
Planet Saver Industries

THE MOST AFFORDABLE, ALL-IN-ONE SOLUTION FOR IN-GROUND POST DECAY AND UPLIFT RESTRAINT

P (610) 377-3270
www.planetsaverind.com

Made in the USA



Acu-Form Roll Forming Equipment
MANUFACTURER OF ROLL FORMING EQUIPMENT

PHONE: (330) 674-4003 EMAIL: WAYNE@ACU-FORM.COM
FAX: (330) 674-4035 WEBSITE: ACUFORMEQUIPMENT.COM



RECOILING

CALL. CUT. DONE.



METAL EXTERIORS
ROOF AND WALL SYSTEMS

- Precision slitting • 36 color options
- Custom blanking • 26 gauge steel

CALL US: 419-896-2200 metalexteriors.com

PROTECTION YOU CAN COUNT ON!



SSG Classic Snow Stoppers
Made of all stainless steel products.

RMG Premium Snow Stopper
Made out of 14-gauge stainless steel.

Snow Stoppers LLC

Contact us and we can give you all the details!
717-209-0418

WE WELCOME WHOLESALERS!

Everlast Metals

ROOF AND WALL SYSTEMS



CONTACT EVERLAST METALS FOR QUICK SERVICE ON SLIT COIL, FLAT SHEETS AND ALL OF YOUR EXTERIOR METAL BUILDING COMPONENT NEEDS.

OFFERING:

- Heavy Gauge Painted Steel or Aluminum
- Solid or Vented FP & RP Panels
- Double Folder Capabilities for Custom Trim or Hard to Find Wall Panels
- Up to 26 Standard Fluoropon® Colors Available
- Quick Turn Around for Slit Coil
- Ready to Ship Fluoropon® and Polyester Aluminum Flat Sheets
- Eight Concealed Fastener Standing Seam Profiles

PLANT LOCATIONS:
Lebanon, PA Bridgton, ME
10 Enterprise Court 24 JR Mains Drive
Lebanon, PA 17042 Bridgton, ME 04009

FOR MORE INFORMATION CALL: 800-418-5057 OR VISIT US AT WWW.EVERLASTMETALS.COM

DMI = BUILDING INVESTMENT PROTECTION



Let DMI complete your building project with Code Approved & Warrantied:

HW & PANGAKE FASTENERS • ANCHORS • PIPE FLASHINGS
REFLECTIVE INSULATION • POLYCARBONATE PANELS
SOLID & VENTED FOAM CLOSURES

www.directmetalsinc.com 855-800-8878

METALCON #2022

PREMIUM QUALITY ROLLFORMING MACHINERY

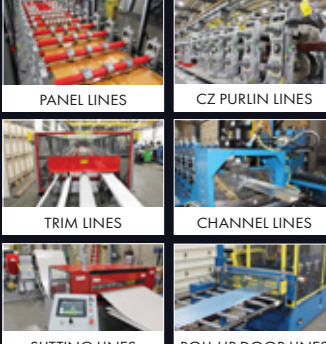

PANEL LINES CZ PURLIN LINES
TRIM LINES CHANNEL LINES
SLITTING LINES ROLL UP DOOR LINES

ASC MACHINE TOOLS, INC.
MADE IN THE USA - EST. 1968

WWW.ASCMT.COM TEL: (509) 534-6600

METALCON #6019

Performance in Post Frame



PLYCO CORPORATION

800.558.5895 • plyco.com

LELAND Specialty Fasteners



Master Grippers® • Grippers MDP® Master Drillers®
Master Tappers® Master Deckers®

Our Powder Coated paint system allows us to match your painted steel supplier's warranty.

LELAND
INDUSTRIES INC.

Made in Canada 1.800.263.3393
www.lelandindustries.com

METALCON #4016

ON TOP SAFETY EQUIPMENT
FAST TRACK FALL PROTECTION
 DESIGNED BY ROOFERS FOR ROOFERS
 716-863-6199 • sales@ontopsafety.com • www.ontopsafety.com

Falcon Safety Cart System

Life Grab Ladder Stabilizer

3RD ANNUAL GARAGE • SHED • CARPORT BUILDER SHOW

JANUARY 24-25, 2024
 Knoxville Convention Center
 Knoxville, TN

**FOR MORE INFORMATION CONTACT MISSY BEYER:
 missy@shieldwallmedia.com
 920-216-3007**

www.garageshedcarportbuilder.com/show-registration

1ST ANNUAL POST-FRAME BUILDER SHOW

June 19-20, 2024
 Branson Convention Center, Branson, MO

**FOR MORE INFORMATION CONTACT MISSY BEYER:
 missy@shieldwallmedia.com • 920-216-3007**

DID YOU KNOW?
 It costs less to buy a Business Card ad than it does to have cards printed.
 We even give your "cards" to more than 40,000 potential customers.

Actual Card Size (3.5" x 2")

**FOR MORE INFO CONTACT GARY REICHERT:
 gary@shieldwallmedia.com • 715-252-6360**

METAL ROOFING MAGAZINE | Rollforming Magazine | Rural Builder | GARAGE • SHED • CARPORT BUILDER FRAMEBUILDING | ROOFING ELEMENTS | Metal Builder

Farming to Metal Forming

Pennsylvania's Sunset Metals rises above adversity

■ By Karen Knapstein

John Hershberger grew up on a Pennsylvania dairy farm. In 1989, at the age of 21 he began helping his father with carpentry jobs; he also helped with his dad's sawmill. "I liked carpenter work and I worked for a crew for the first two years, then started my own crew at the age of 23," John recalls. "Things were different back then; we worked by the hour anywhere from \$6.50 to \$9 per hour, depending on your experience." He and his crew spent the next five years building new homes, dairy facilities, garages, and pole barns.

In 2002, John added his own farm to his business regimen. "I bought a 238-acre farm, and in 2005 we started milking cows, but I still had my carpentry business. We milked cows for five years and raised our own crops, plus worked in the carpentry business," he explains. "Then in 2010 we sold our dairy cows, as we were just not making any money with them. We bought a herd of beef cows and kept raising our own crops, etc. for three more years."

FOUNDING SUNSET METALS

It was in 2013 that John made a major change in his business plans. He and his wife Barbara sold the farm and cows, and moved their family to the Cambria County, Pennsylvania, area. (The family included their eight children — five sons and three daughters — and their married son's wife.)

John and Barbara bought a 24-acre farmette with the goal of operating a home-based business that wasn't a farm. "I was tired of working away from home, so we started a metal roll forming business." With more than 20 years of experience working as a builder, and after researching what the roll forming business was about, John and his family believed they had the makings to be successful at operating a metal forming business.

"We had the opportunity to buy out a local guy by the name of Stephen Zook," who was moving to Indiana. "On September 3, 2013, we bought his business, and we operated at that location until July 2014." The equipment that came with the business included an Acu-Form roll former, slitter, and uncoiler; a



After the fire, Sunset Metals built back bigger and better, with an eye to building on past successes. PHOTOS COURTESY OF SUNSET METALS

Tennsmith brake; and a "really old" hemmer.

It took a couple years for the business to become well established. "The first two years the business was slow," recalls John. "I would work out in the wintertime, as there were hardly any

The Way We Roll))



A remnant of the original roll-forming facility: An addition that wasn't quite complete.

orders. But then the next Spring we hired our first employee, Danny Byler. Our business was picking up and we had our hands full to keep up with the orders. By now we had some trim roll formers and almost every day I had to work after hours to get all the orders done for the next day.”

In July 2014, they moved the operation to a new 60' x 120' metal shop at the company's current location near Ebensburg. As the company continued to grow, it added equipment and employees. In January 2022, John and Barbara sold half of the business to their 29-year-old son Marvin and his wife Emma.



UNEXPECTED LOSSES

Unfortunately, cancer took Danny, the company's first employee, from them in July 2022; he is still missed. Then, in February 2023, fire broke out in the shop. (See *Up From the Ashes*, page 34.) The building, which housed the entire business, was almost a total loss. Only the newest addition, which wasn't yet finished, was left standing. But the community and the extended Hershberger family acted quickly and all pulled together to rebuild. The business was rebuilt and operations were split into several buildings, which will prevent a total loss should fire ever break out again. After three months of refurbishing equipment and rebuilding the facility, business resumed in mid-May.

THE PRESENT & FUTURE

“Now we have five full-time employees and a full line of roll forming equipment,”

John reports. The equipment in the shop now includes a full complement of Acu-Form machines, including an ag panel with post-cut shear, two uncoilers, a coil pender, a hemmer, a snow guard machine, a ridge cap machine, a J channel machine, large and mini corner machines, a residential corner machine, and a perforator. Because of the fire, almost all have been rebuilt to like-new condition by Acu-Form.

The company's trim roll-forming machine from Metal Rollforming Systems (MRS) also suffered damage in the fire. Rather than send the four-profile machine back to the manufacturer to rebuild, the Sunset Metals crew restored it themselves. “It didn't seem feasible to truck it all the way back to Washington [from Pennsylvania] when we felt we could do it ourselves,” explains John. To restore the machine, it was cleaned, sandblasted and painted, and put back

together with new bearings and parts sourced directly from MRS. “They were very helpful; they did their part,” John adds.

The company's 12' brake from Stoll Metal Works also sustained damage in the fire. “It was about a year old. We sent it back to Stoll and they made it look like brand new again. And they had it done in about five or six weeks. You wouldn't even know that it went through a fire.”

The company recently added two portable machines to its equipment lineup to satisfy customer demands. In December 2021, they purchased a New Tech SSQ II portable roll former that makes standing seam panels. In June of this year, they acquired a board and batten profile machine from Eastside Machine Company. “We're just getting into roll forming on the jobsite,” John says. “In our area, we don't sell a lot of standing seam, but we do get calls about it.”

In their area, Sunset Metals sees the most demand for G-rib or ag panels for residential and commercial reroofing. The company supplies roofers and builders in Cambria, Indiana, Blair, Allegheny, Armstrong, Washington, and West Moreland counties. John explains there are a lot of old coal towns in their region and owners generally don't want to get too fancy when putting on a new roof. "As you get closer to Pittsburgh there's more demand for standing seam and metal shingles." (They also supply roofers with ProVia metal shingles.)

Sunset Metals sticks with suppliers and products they believe in. "We buy all our coils through Hixwood. We did our research on paint systems and feel that the Beckers Paint System is an excellent product! Currently we are the only one in our area that offers this paint system. We buy all our fasten-



Sunset Metals can now supply Pennsylvania roofers with the components and tools they need.

ers from Levi's Building Components, and we get our Uni-Vent, Emseal, caulk, boots, etc. from Northern Building Components." The company's goal is to always have customers' orders ready within 24 hours.

Built with a strong work ethic and dedication to family values, Sunset

Metals has hit its stride. John declares, "Our 2022 business was good; we had more sales than the prior year. 2023 is strong so far, after our three-month shut down due to the fire. We see an increase in our sales every year, so we are still growing it seems, and want to give all honor to God." RF



715-644-0765 — Fax: 715-644-0994

Hixwood Metal is the premier source for all your steel coil, blank flat stock, and slit coil needs.



- Striving every day to meet the most stringent demands of our quality minded coil customers.
- We have over 20 smooth and 15 textured colors available in the ever popular BeckeryTech H.D.P.E paint system.





Give us a call for all your coil and building accessory needs!

COIL UPENDER

5-TON - ELECTRIC MODEL

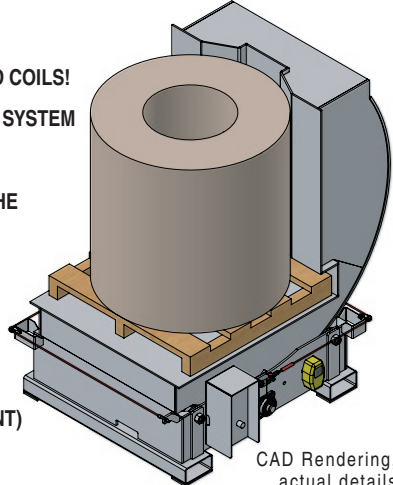
1. BALANCED DESIGN
2. NO MORE DAMAGED COILS!
3. HEAVY DUTY DRIVE SYSTEM
4. 5-TON CAPACITY
5. DESIGNED TO DO THE WORK GENTLY
6. HYDRAULIC MODEL AVAILABLE
7. LOAD COIL FROM END OR SIDE
8. COMPACT SIZE: 50" X 64" (FOOTPRINT)



CAD Rendering, actual details may vary.



SOLOMON STOLL - JOEL LESHER
6600 BACK LANE WAYNSBORO, PA 17268
PHONE: **717-387-5572**

CALL NOW FOR A FREE BROCHURE

GET MORE INFORMATION ABOUT PRODUCTS & SERVICES SEEN IN THIS ISSUE. HERE'S HOW:



If you are looking for more information from companies featured in this issue, fill out this form.

Mail the completed form to us, and we will have those companies get in touch with you. There's no need to fill out multiple forms; we'll do the legwork for you.

Name (please print) _____

Signature (required) _____

Company _____

Address _____

City _____ State _____ Zip _____

Telephone (_____) _____

E-mail _____ Date _____

Please check one or more boxes to subscribe FREE/Renew for 3 years:

Garage, Shed & Carport Builder Magazine Frame Building News Metal Roofing Magazine

Rural Builder Rollforming Magazine Roofing Elements Magazine Metal Builder

I would like to receive my subscription: By Mail Digitally

Check this box if you wish to receive our Construction Express newsletter and offers from our partners.

Email address is required to receive newsletter.

**CONTACT NAME & EMAIL (OR) NAME & PHONE NUMBER ARE REQUIRED.
WITHOUT THIS INFORMATION WE WILL NOT PROCESS THE REQUEST.**

**SELECT A MAXIMUM OF 5 COMPANIES
TO REQUEST INFORMATION FROM:**

Company Name: _____ PAGE: _____

Company Name: _____ PAGE: _____

Company Name: _____ PAGE: _____

Company Name: _____ PAGE: _____

Company Name: _____ PAGE: _____

I understand that by providing the above information I hereby consent to receive communication regarding my subscription via US Mail, telephone, and e-mail sent by Rollforming Magazine.

RF OCT/NOV 2023

CHECK WHICH TITLE APPLIES TO YOU:

- President
- Owner
- Partner
- General Manager
- Sales Manager/Rep
- Engineer/Architect
- Vice President
- Foreman
- Installer
- Other _____

PLEASE CHECK THE PRIMARY CATEGORY THAT DESCRIBES YOUR BUSINESS:

- Builder, Dealer, Remodeler or Installer
- Roofing Contractor
- Metal Roofing Contractor
- Building Material Dealer/Distributor
- General Contractor/Remodeler
- Manufacturer/Rep of Manufacturer
- Architect/Specifier
- Construction Consultant/Engineer
- Building Owner/Developer
- Other (Please Specify) _____

ENGAGED IN THE FOLLOWING APPLICATIONS:

- Gutters/Accessories
- Institutional
- Residential
- Agricultural
- Commercial
- Industrial

CSI: Expansions & Challenges

Our Mid-Year Survey included questions about concerns and additions for the remainder of 2023. Some things remained constant across “All Respondents,” “Metal Roofing Contractors,” “Post Frame,” “Agricultural” and “Rollforming Subscribers,” but there were some interesting differences.

All groups included Employees (support) and New Products. Other areas of expansion across the various groups were Employees (construction), Metal Forming

Equipment, Manufacturing Equipment, Trucks and Jobsite Equipment.

More Rollforming Subscribers listed New Products as number 1. It was number 3 across the other groups and Rollforming Subscribers were 8-14% higher than the other groups.

The Concerns demonstrated more similarity. Across all groups Finding Employees, Interest Rates, Cost of Materials and Inflation were listed as concerns one through four. In all groups other than Residential-Single Family, number

five was Retaining Employees.

Some nuggets looking at the data:

- One third of Rollforming Subscribers are looking at adding Metal Forming Equipment.
- Concerns about Domestic Politics only made the top five in one category, but the concern level was still relatively high, varying between 23% and 39%. Rollforming Subscribers had the lowest level of concern across the groups.
- The resurgence of COVID is apparently no longer of concern. [RF](#)

Which of the following (if any) do you plan to add or increase in 2023?

All Respondents		Metal Roofing		Post Frame	
Employees (construction)	33%	Employees (support)	35.42%	Employees (support)	37.50%
Employees (support)	33%	Employees (construction)	33.33%	Employees (construction)	31.25%
New products or building types	30%	New products or building types	33.33%	New products or building types	31.25%
Manufacturing equipment	28%	Metal forming equipment	29.17%	Manufacturing equipment	28.13%
Trucks	25%	Manufacturing equipment	29.17%	Trucks	25%

Residential – single family		Agricultural		Rollforming Subscribers	
Employees (construction)	50%	Employees (construction)	40.63%	New products or building types	43.33%
Employees (support)	31.82%	Employees (support)	37.50%	Manufacturing equipment	43.33%
New products or building types	29.55%	New products or building types	34.38%	Employees (support)	40%
Jobsite equipment	25%	Manufacturing equipment	34.38%	Metal forming equipment	33.33%
Trucks	25%	Trucks	31.25%	Jobsite equipment	30%

Q23 Which of the following (if any) do you see as a challenge in 2024?

All Respondents		Metal Roofing		Post Frame	
Inflation	59%	Inflation	60.42%	Inflation	59.38%
Interest rates	51%	Finding employees	54.17%	Finding employees	56.25%
Finding employees	49%	Interest rates	52.08%	Interest rates	53.13%
Cost of materials	45%	Cost of materials	47.92%	Retaining employees	40.63%
Retaining employees	32%	Retaining employees	31.25%	Cost of materials	37.50%

Residential – single family		Agricultural		Rollforming Subscribers	
Finding employees	63.64%	Finding employees	59.38%	Inflation	56.67%
Inflation	54.55%	Inflation	53.13%	Interest rates	53.33%
Interest rates	56.82%	Interest rates	50%	Finding employees	43.33%
Cost of materials	50%	Cost of materials	46.88%	Cost of materials	30%
Domestic politics and policy	38.64%	Retaining employees	40.63%	Retaining employees	26.67%

CERAM-A-STAR® 1050

Proven Performance.

The strongest, most durable and best performing SMP coating technology.

- ↗ Protecting your brand and reputation since 2005
- ↗ Best in class gloss and color retention for long lasting performance

Made Easy.

Now available in a standard color palette program. CERAM-A-STAR® 1050 Select makes color complexity a thing of the past.

- ↗ Reduced complexity to increase operational efficiencies
- ↗ Improved availability resulting in quicker turns on projects

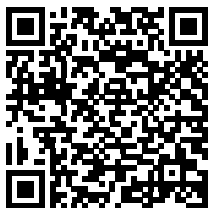

Step up to
proven performance
that's made easy.



AkzoNobel

coilcoatings.akzonobel.com/us/ceram-a-star