

Rollforming Magazine

AUGUST/SEPTEMBER 2024
Vol. 7, No. 4

www.rollformingmagazine.com

EXCLUSIVELY DEVOTED TO CONSTRUCTION ROLL-FORMING PROFESSIONALS

CONSTRUCTION
ROLLFORMING SHOW
PREVIEW

REGISTER
NOW!

GEARING UP FOR THE CONSTRUCTION ROLLFORMING SHOW

CONSTRUCTIONROLLFORMINGSHOW.COM



graberpost.com • BOOTH #220



717-387-5572 • BOOTH #209

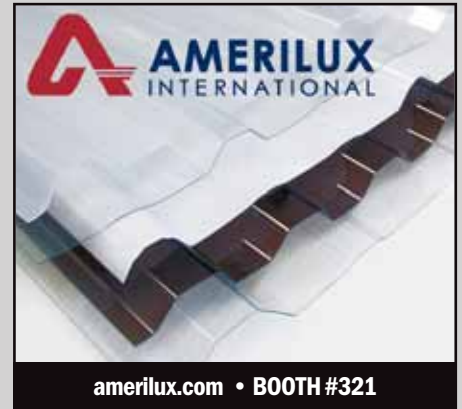

amerilux.com • BOOTH #321



unitedsteelsupply.com • BOOTH #401



www.van-mark.com • BOOTH #615



CX5 – Auto Decoiling
& Storage System

swimachinery.com • BOOTH #301



rfoil.com • BOOTH #108

GRAND RAPIDS, MI • SEPTEMBER 18 & 19, 2024

**FLIP TO
SPECIAL
SECTION:
METAL
BUILDER**



D
Y
N
A
M
I
C

F
A
S
T
E
N
E
R

2
0
2
4



DYNAMIC FASTENER

Everything for the Metal Builder & Roofer®

2024 TOOL & FASTENER HAND GUIDE

You supply the crew. We'll supply the rest®

MAIN OFFICE		KANSAS CITY	CHICAGO	HOUSTON	LAS VEGAS	MEMPHIS	ST. LOUIS	ST. PAUL					
9911 E. 53rd St.	Raytown, MO 64133	2575 W. LeMoynoye St.	Melrose Park, IL 60160	1414 Brittmoore Rd.	Houston, TX 77043	6455 Dean Martin Dr. Ste J	Las Vegas, NV 89118	3700 Cherry Rd.	Memphis, TN 38118	12800 Pennridge Dr.	Bridgeton, MO 63044	2316 Territorial Rd.	St. Paul, MN 55114
816-358-9898 Local	800-844-1199 Fax	708-615-1450 Local	708-615-1451 Fax	713-647-8665 Local	713-647-8635 Fax	702-566-1555 Local	702-566-0175 Fax	901-369-8000 Local	901-369-0105 Fax	314-739-8771 Local	314-739-8691 Fax	651-644-1212 Local	651-644-1124 Fax
800-821-5448 Net		800-573-7787 Net		800-988-5490 Net		866-936-8665 Net		800-727-0288 Net		800-444-0515 Net		800-755-2426 Net	



D-F® RIVET BOSS®
PG. 92, 93

D-F® ultra-premium nut runners

With Mag 10 **\$3.25**
5/16 x 2-9/16" 100 **\$2.30** PG. 52



DYNA-GUARD®

D-F® SNOW RETENTION FOR METAL ROOFS

PG. 66-69



DEWALT

DW268 **\$189.85** PG. 4



Milwaukee

12V Rivet tool. **FREE** 3" battery. Shown with optional 6" extension.

2550-22 **\$377** PG. 31



With **Dyne-Coat®**

D-F® SELFDRILLERS PG. 74-83



D-F® DYNA-CLAMPS®

DC-U 600+ **\$5.95** PG. 68



leaky metal roof?

D-F® DROP-STOP® PG. 56, 57



D-F® DYNA-FLASH®

#3 **\$6.63** PG. 61-63

PRICES GUARANTEED UNTIL MARCH 31, 2025 OR WHILE SUPPLY LASTS - SUBJECT TO CHANGE WITHOUT NOTICE

(800) 821-5448 Order online @ www.dynamicfastener.com

© Copyright 2024 D.F.S.



Call 800-821-5448 for your **FREE** 140 pg 2024 Hand Guide

See You In September!

■ By Missy Beyer

As I write this, we have just closed the books on our first ever Post-Frame Builder event. One of the great things about Shield Wall Media is that we never stop growing. That is particularly true of our Construction Rollforming Show. This, our fifth Construction Rollforming Show, is already the biggest ever and is still growing. We expect to sell out the available space at DeVos Place in Grand Rapids, Michigan, this September 18-19.

If you roll form or use benders or brakes to form panels, channels, studding, soffits, gutters, carport, or other construction components, this is your show to attend. If you want to reach those that do their own fabrication and buy materials and components in pallet, container, or truck-load lots, you



want to be an exhibitor at the Construction Rollforming Show.

Now is the time to confirm your spot at the show whether it be as an exhibitor or an attendee. September is right around the corner. You can find attendee registration information for the show online at constructionrollformingshow.com and I welcome your calls or emails to reserve your exhibitor space at the show. Maybe you just have a great idea for the show. Drop me a line and let me know what you have in mind.

See you at the Show in September!

Missy Beyer, Director of Events
missy@shieldwallmedia.com
920-216-3007

Editor's Note))

Five Years and Counting

■ By Karen Knapstein

Just a week ago, we wrapped up the first annual Post-Frame Builder Show (in Branson, Missouri) and are deep in the preparation stages for the Construction Rollforming Show (CRS). Next month, on September 18-19, the CRS ventures north as it debuts in downtown Grand Rapids, Michigan, at DeVos Place.

You'll find that a large part of this edition is dedicated to preparing you to attend the Construction Rollforming Show. Included within these pages are a preview article with some of the activities

you can look forward to, the layout of the expo floor, and detailed list of all the companies that will be exhibiting that includes their contact information. To round out the pre-show coverage, we've rounded up some recommendations for family-friendly activities and dining. (I recommend that you keep this edition — even if you can't attend the show — to use as a directory for your metal-forming material and equipment needs.)

We also squeezed in a couple of features. As I've probably mentioned before, many subscribers have told us

that they enjoy reading about their peers ... especially regional roll-forming shops. After a brief hiatus, the feature returns in this edition with a profile of Emanuel Hershberger's Michigan-based business, The Metal Shop. We think you'll enjoy reading about this family-run business.

If you'd like your roll-forming shop featured in a Way We Roll article, please contact me at karen@shieldwallmedia.com or call me at 715-513-6767.

There are thousands of stories out there and we'd be honored to share yours.
RF

Contents))



8: Top Performance
Find Your 'Hidden' Roll Former

46: The Way We Roll
The Metal Shop

SPECIAL SECTION

12: Preview: Construction
Rollforming Show
Show Features & Highlights

16: Product Feature
New Products At The
Construction Rollforming Show

20: Exhibitors

38: Expo Floorplan
Your Map To Success

44: Adventures Await
Things To Do In Grand Rapids

56: Construction
Survey Insights



Departments))

- 3 Show Director Note
- 3 Editor's Note
- 6 Breaking News
- 51 Business Connections
- 55 Steel Market Update
- 56 Construction Survey Insights
- 57 Products & Services



AUGUST/SEPTEMBER 2024
Vol. 7, No. 4

Rollforming Magazine

EXCLUSIVELY DEVOTED TO CONSTRUCTION ROLLFORMING PROFESSIONALS

CONSTRUCTION ROLLFORMING SHOW
 REGISTER NOW!

GEARING UP FOR THE
CONSTRUCTION ROLLFORMING SHOW

CONSTRUCTIONROLLFORMINGSHOW.COM

graberpost.com • BOOTH #229

717-287-5272 • BOOTH #209

amerilux.com • BOOTH #321

unitedsteel.com • BOOTH #481

www.vanmark.com • BOOTH #515

swimachinery.com • BOOTH #301

GRAND RAPIDS, MI • SEPTEMBER 18 & 19, 2024

rfoil.com • BOOTH #308

On The Cover:

Be sure to visit with these exhibitors at the Construction Rollforming Show in Grand Rapids, Michigan, Sept. 18-19.

INDEX OF ADVERTISERS

Company	Page #
AceClamp	35
Acu-Form	30, 37, 51
AkzoNobel	7
AmeriLux International	CVR
ASC Machine Tools Inc.	23, 37, 52
Aztec Washer Company	51
Beck Automation	41
Bradbury Group	25, 37
Buffalo River Truss LLC	52
Daystar	37
Direct Metals Inc.	53
Dripstop™	21
Dynamic Fastener	IFC
Ecolit LLC	Flip 4-5
Englert Inc.	13
Everlast Metals	51
Golden Rule Fasteners	51
Graber Post Buildings, Inc.	CVR , 37, 42
Hershey's Metal Meister	37
Hixwood	30, 37
Levi's Building Components	29
Little Harveys	9, 37
Marion Manufacturing	51
Metal Rollforming Systems	27, 37
METALCON	Flip 2
Mid South Aluminum	17
Mill Steel Company	26
New Tech Machinery	47
Planet Saver Industries / GreenPost	51
Progressive Metals	19
Red Dot Products, LLC	37, 53
RetroFitClip	52
rFOIL Reflective Insulation	CVR, 33, 51
Roll Former LLC	49
Samco Machinery	53
SmartBuild Systems	28
Snap Z	33
SpeedLap LLC	52
Star 1 Products	43
Stoll Metal Works	CVR, 35
SWI Machinery	CVR, 15
T&H Lemont	37
Trac-Rite Door	Flip 9
Trachte Building Systems	Flip 9
Triangle Fastener Corporation	24
United Steel Supply	CVR, 11, 51
Van Mark Products Inc.	CVR
Wildcat LLC	37

YOUR PRIVACY IS IMPORTANT TO US

Unrelated third parties often attempt to sell mailing lists for what they say are our publications. You can be assured that WE DO NOT, HAVE NOT, AND WILL NOT EVER SELL OUR SUBSCRIBER LISTS. We will also NOT sell the attendee or exhibitor lists from our shows. We do provide attendee lists to the exhibitors free of charge and as a courtesy for their support, but we NEVER provide this or any other information to independent vendors.

Gary Reichert,
Publisher, Shield Wall Media

Rollforming Magazine

Managing Editor:

Karen Knapstein
karen@shieldwallmedia.com
715-513-6767

Editorial Staff:

Dan Brownell, Linda Schmid

Circulation/Subscriptions:

Barb Prill
barb@shieldwallmedia.com
920-471-4846

Publisher/CEO:

Gary Reichert
gary@shieldwallmedia.com
715-252-6360

Director of Events:

Missy Beyer
missy@shieldwallmedia.com
920-216-3007

Executive/Advertising Assistant:

Kathy Budsberg
kathy@shieldwallmedia.com

Advertising/Show Assistant:

Cari Ullom
cari@shieldwallmedia.com

Graphic Designers:

Tom Nelsen, Kevin Ulrich

Rollforming Magazine (ISSN: 2639-6742) (Volume 7, Issue 4) is published six times per year (March, May, July, September, November and December) by Shield Wall Media LLC, 150 Depot St., Iola, WI 54945. Periodical postage paid at Iola, WI, and at additional mailing offices. Canadian Agreement Number: 40665675. POSTMASTER: Send address changes to Rollforming, Barb Prill, PO BOX 255, Iola, WI 54945. Copyright 2024 Shield Wall Media LLC. Rollforming Magazine and its logo are registered trademarks. Other names and logos referred to or displayed in editorial or advertising content may be trademarked or copyright. Rollforming Magazine assumes no responsibility for unsolicited materials sent to it. Publisher and advertisers are not liable for typographical errors that may appear in prices or descriptions in advertisements. Mailed free to roll forming contractors and their suppliers throughout North America. Others may subscribe: \$19.98 for 1 year, \$36.98 for 2 years, and \$50.98 for 3 years.

GO TO FLIP PAGE 11
TO SUBSCRIBE
TO MORE
FREE MAGAZINES



Next Issue:

- Renting Out Portables
- Rolling Textured Coatings



The mikeroweWORKS Foundation Surpasses \$11M in Trade Scholarships

This year, the mikeroweWORKS Foundation is awarding \$2.4 million in work ethic scholarships to more than 300 aspiring tradespeople. As in past years, 2024 recipients include a broad mix of plumbers, electricians, welders, mechanics, pipe fitters, HVAC specialists, blacksmiths, cosmetologists, and many other skilled workers seeking to enter careers that don't require an expensive four-year degree.

"It's been really gratifying to help train the next generation of skilled tradespeople," said Mike Rowe, CEO of mikeroweWORKS. "The opportunities to prosper in the trades today are astonishing, and shining a light on those opportunities has been a real privilege."

With this latest round of scholarships, Rowe's foundation will have awarded nearly \$12 million in work ethic scholarships to more than 2,000 Americans, making mikeroweWORKS the largest trade school scholarship fund in the country. Along with its scholarship program, mikeroweWORKS is also leading the charge to reinvigorate the trades by challenging the myths and misperceptions that keep so many people from exploring a vocational career.

"It's not enough to simply award scholarships to qualified applicants," said Rowe. "If we really want to close the skills gap, we need to change perceptions in the broadest possible way. That means better PR for the trades. We need to show Americans that lots of skilled tradespeople are making a very comfortable six-figure salary, setting their own schedules, and finding real meaning and fulfillment in their work."

For nearly a decade, the ratio of baby boomers retiring to those entering the



Scholarship recipient Zachary White, RHVAC



Scholarship recipient Carlyn McClelland, Construction Estimator

workforce has been 5:2, according to Skillwork. The resulting "skills gap" has widened, and the Bureau of Labor Statistics reported in May that there are 8.1 million open positions—the majority of which do not require a four-year degree—and caused a labor shortage that's left our workforce profoundly out of balance. Meanwhile, the cost of college has soared, leaving nearly 44 million Americans with \$1.6 trillion in student loan debt. And yet, high school graduates are still encouraged—often by well-meaning parents and guidance counselors—to borrow vast sums of money to attend universities that continue to raise their tuition, leaving millions indebted and untrained for the many vocational jobs waiting to be filled.

"Ever since we took shop class out of high school, we've been telling our kids that the best path for the most people is a four-year degree," said Rowe. "And for decades now, we've been lending money we don't have to kids who can never pay it back, so they can buy a diploma that no longer guarantees them a job. That has to

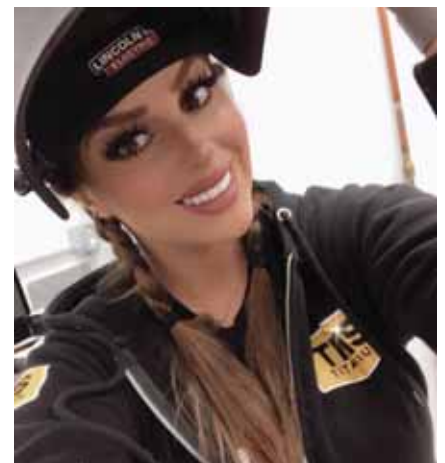

Scholarship recipient Chloe Hudson, Welder

stop. At mikeroweWORKS, we're telling an honest story about college debt, and making a persuasive case for the many opportunities that exist in the skilled trades. That's what we've been doing since Labor Day of 2008, and that's what we'll be doing this Labor Day. And hopefully, for many Labor Days to come."

For more information about the mikeroweWORKS Foundation, visit mikeroweworks.org. RF

CERAM-A-STAR® 1050

Proven Performance.

The strongest, most durable and best performing SMP coating technology.

- ↗ Protecting your brand and reputation since 2005
- ↗ Best in class gloss and color retention for long lasting performance

Made Easy.

Available in a standard color palette program. CERAM-A-STAR® 1050 Select makes color complexity a thing of the past.

- ↗ Reduced complexity to increase operational efficiencies
- ↗ Improved availability resulting in quicker turns on projects



Step up to
proven performance
that's made easy.



Overall Equipment Effectiveness

OEE: Uncovering Your Hidden Roll Former

■ By AMS Controls

If you could produce more, could you sell it?

If you said yes after reading the question above, congratulations! You are in position to significantly increase your revenue any time your metal forming machine is running. This is an enviable position indeed.

So how do you ramp up production to meet sales demand? One way to scale up: purchase more equipment, add another line and more staff. The line is producing well, demand is high. Why not add a line to boost production, and sell more.



Makes sense. Does it really? Can you really take on the capital expense of a large equipment purchase? Will sales be high enough to pay for the added equipment, let alone what it would cost to hire and train more workers? What happens if the market softens and demand decreases? Is there another way to increase production without the risk of a large capital expense?

THE HIDDEN ROLL FORMER ON YOUR PLANT FLOOR IS HIDING IN PLAIN SIGHT

OEE uses availability, speed and yield to help you understand how your equipment is performing.

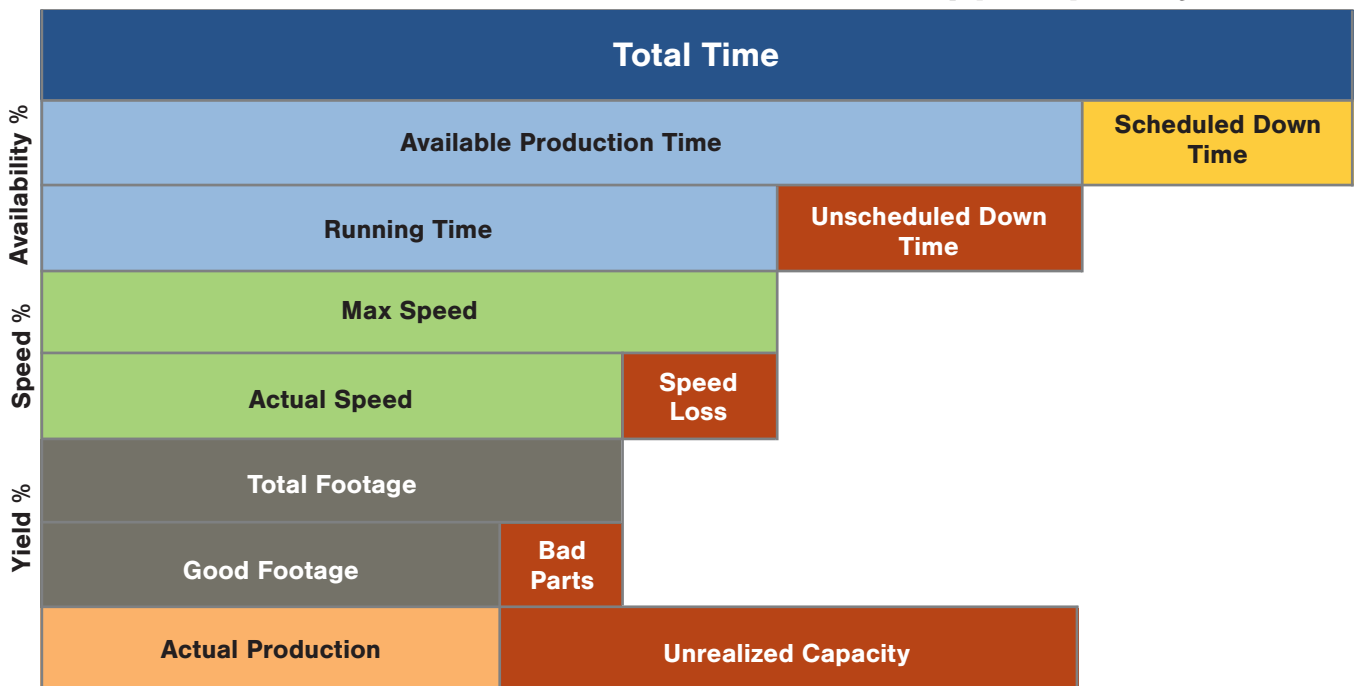

OEE analyzes availability, speed and yield to provide a metric to measure the efficiency of a specific machine.



Trust Only Kynar 500!



336.468.2061



4309@emailbyfax.com



336.468.4309



Signature
Weathered Wood



Signature
Dark Cherry



Signature
Red Oak



Signature
Natural Pine



Digital
Weathered Wood



Digital
Dark Cherry



Digital
Red Oak



Digital
Natural Pine



Stackstone
Ash



Stackstone
Shadow

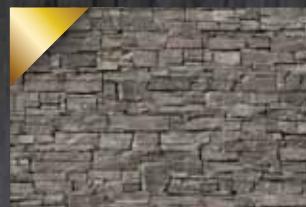

Stackstone
Smoke



Stackstone Rotate
Ash



Stackstone Rotate
Shadow

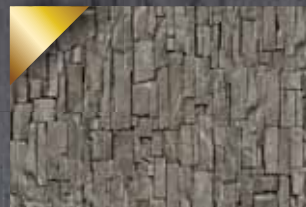

Stackstone Rotate
Smoke



Using OEE (Overall Equipment Effectiveness) as a standard manufacturing measurement for equipment effectiveness, we can quickly determine if equipment is running at peak capacity. Without delving too deep into the mechanics of OEE measurement, OEE analyzes availability, speed and yield to provide a metric to measure the efficiency of a specific machine. The higher the percentage, the closer to maximum capacity the machine is running. Generally, most roll formers in the U.S. have an OEE of 20% to 60%.

TRUTH: If a piece of machinery has an OEE of 50% or lower, it is only producing half of what it could potentially produce. Which means you've found your hidden roll former!

FINDING YOUR MACHINE'S TRUE OEE

The first step to understanding the capacity of your manufacturing processes is to determine the OEE of your individual machinery. The process to uncover your machine's true OEE starts first with benchmarking and the collection of reports to measure equipment availability, performance and output. The quality of these numbers are very important to ensure accurate benchmarks. As such, manual reporting that relies on operators to document run time, down time, changeovers and scrap are not reliable sources of good data. Whenever there is a human element required for the input of data, it's impossible to expect accurate reporting.

Analyzing the OEE numbers of a machine quickly helps you identify bottlenecks in your processes.

If you are fortunate and have a machine controls partner that understands the importance of OEE and reporting, you are in luck! Machine controls are perfectly positioned to collect valuable data for OEE analysis, all without burdening operators with any manual reporting.

WHAT TO DO WITH YOUR BENCHMARK OEE NUMBERS

Analyzing the OEE numbers of a machine quickly helps you identify bottlenecks in your processes. Bottlenecks could include issues such as coil changes taking too long, too many unscheduled [stops for] maintenance and repairs, or even high scrap numbers.

Once bottlenecks are identified, the next step is to determine the root cause of the problem. Accurate reporting is critical here to uncover the root causes of the problem. An examination of downtime codes of the bottleneck in question is a good place to start. Of all the downtime codes listed, which are the most common? Which take the longest



The right roll forming machine controller can be adapted to the machine type and offer improved accuracy, efficiency, and ease of use.

PHOTO COURTESY OF AMS CONTROLS*

to resolve? Which downtime, if solved, will have the biggest impact on productivity? Putting together a cross-functional task force made up of both project managers and operators can help with the process of determining root causes and also devising solutions to reduce or eliminate bottlenecks.

An AMS Controls white paper features an in-depth review of OEE and continuous improvement. It contains more information on how to dive into root causes and identify areas of improvements that can yield the highest level of benefit. [<https://www.amscontrols.com/kb/continuous-improvement-in-roll-forming/>]

OEE AND CONTINUOUS IMPROVEMENT CAN DO SO MUCH MORE

If you want to know about the true capacity and effectiveness of your machinery, identifying the OEE of your machinery is an excellent starting point. Once the OEE has been identified, pairing OEE with your continuous improvement efforts can help you tap into the hidden roll former in your plant to improve not only your capacity, but ultimately your margins and profitability. Plus, if your OEE shows your machine truly is running at capacity, you now have the documentation to prove and justify a capital expense.

About AMS Controls

AMS Controls has a complete production management system to optimize the manufacturing of panels, purlins, trim, studs, and more. Since 1977, AMS Controls has sold 12,000+ controllers worldwide. AMS Controls solutions can be used with any brand of roll former or folder to eliminate mistakes, manage coil inventory, and track production. **RF**



For more titles, check out Shield Wall Media online: www.shieldwallmedia.com



BUILDING FOR TOMORROW.

At United Steel Supply, our commitment to the metal roofing industry is second to none because it's the only segment we serve. We're dedicated to championing our industry's recovery — offering nationwide distribution, full slitting capabilities, just-in-time delivery and the highest quality Galvalume[®], galvanized and prepainted steel coils in the nation.

The future is bright in our industry and we will be here to grow with you.

To learn more, contact your USS sales representative.



UnitedSteelSupply.com | 512-263-0954



Best Practices • Expert Advice

Build Your Business At The 2024 Construction Rollforming Show

■ By Karen Knapstein

On September 18-19, the fifth installment of the Construction Rollforming Show will take place at the DeVos Place convention center in downtown Grand Rapids, Michigan. This show is an event that is developed and produced specifically for metal component manufacturers for the construction industry. The location was strategically selected by Shield Wall Media CEO Gary Reichert. He explains, “Michigan, Wisconsin, and the northern Midwest and Great Lakes states are a hotbed of metal forming and roll forming for the construction industry. Typically, shows are farther south. We thought a great show for roll formers should be a little closer to home.”

While the location is new, what remains the same is the tried-and-true, high-quality, manufacturer-focused show that people in the construction



metal-forming industry have come to expect. The Construction Rollforming Show was created for rollformers, not contractors. This show is for anyone who needs to learn about construction metal forming or needs to speak directly with manufacturers and suppliers who sell in pallet, container, or truck-load lots. It is also the perfect opportunity for anyone who is considering making the transition

to manufacturing their own metal trims, metal panels, gutters, or perhaps even to make their own post-frame building kits. Attendees can learn what it takes to get started in manufacturing metal components and how to be competitive and successful in this essential industry.

Some of the main reasons people attend trade shows are to learn about what’s going on in the industry, to find suppliers, and to learn about new products. The expo floor will be filled with exhibitors that are relevant to the construction roll forming industry; there are no exhibitors who are not relevant to this specific industry.

Attendees can learn directly from subject matter experts who have spent years gaining knowledge. The educational schedule is set so attendees and exhibitors can maximize their opportunities to make connections on the expo floor. Planned topics (subject to change due to speaker availability) include, but are not limited to:

- Machine Maintenance
- Condensation Control
- Automation & Production
- Coil Quality & Variation
- Selecting Equipment That Meets Your Needs



This year's Construction Rollforming Show will take place at the DeVos Place convention center in Grand Rapids, Michigan.



Portable Roll Forming

Keep the profit in your pocket

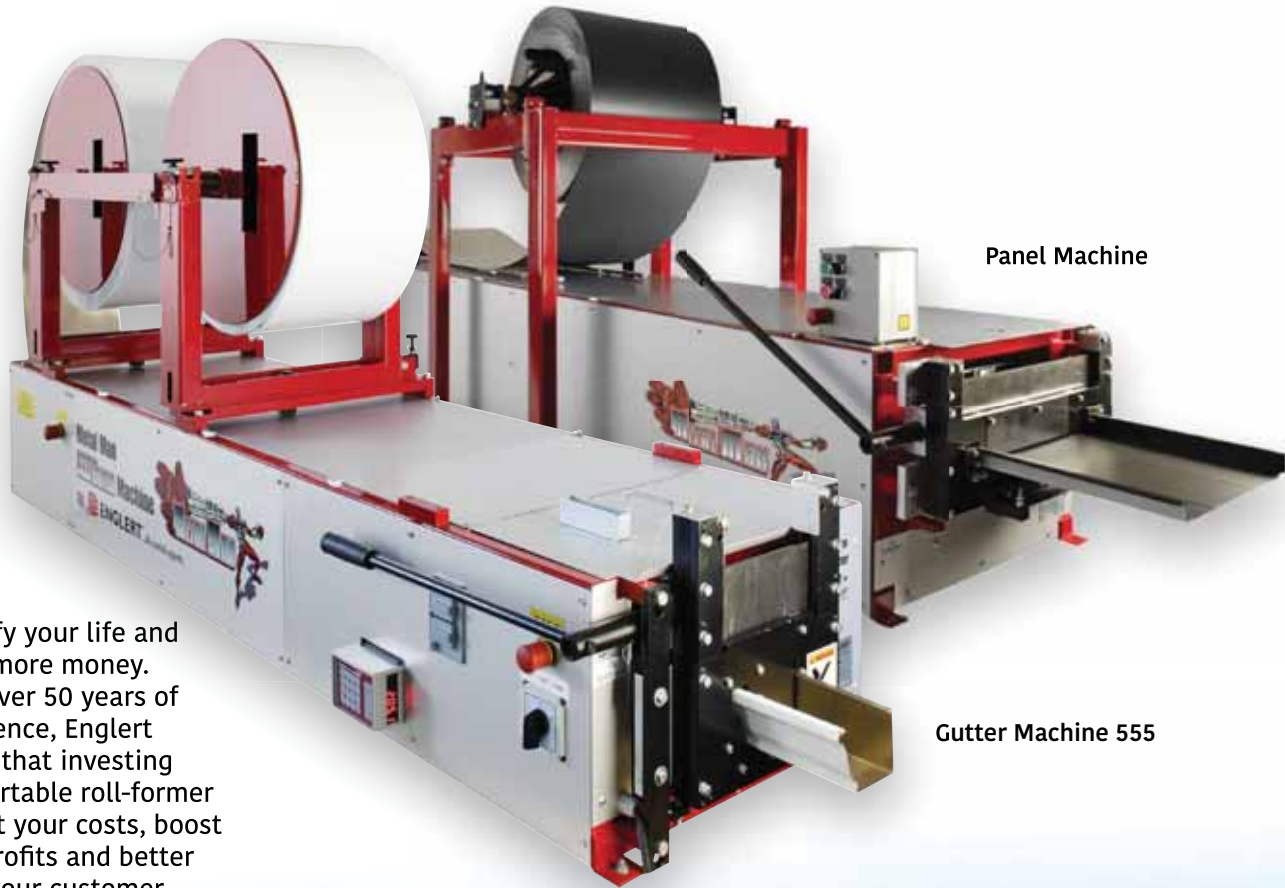

Panel Machine

Gutter Machine 555

Simplify your life and make more money. With over 50 years of experience, Englert knows that investing in a portable roll-former can cut your costs, boost your profits and better meet your customer needs in their projects.



1.800.ENGLERT
info@englert.com
www.englertinc.com



Scan here to learn more about Englert's portable roll forming machines

• Working With Aluminum

The schedule allows question and answer sessions after each presentation.

As of this early writing, more than 60 suppliers and manufacturers are confirmed to exhibit; in fact, exhibit space is nearly sold out. Attendees can speak one-on-one with coil and fastener suppliers, equipment manufacturers, software developers, equipment control specialists, coating specialists, and more. There will be exhibitors to provide attendees with all the necessary information needed to set up or grow a construction metal-forming business.

There will be on-site demonstrations of tools, equipment, software, machines, and more. Among the exhibitors are Hershey's Metal Meister, SWI Machinery, and Formwright (New Tech Machinery), which will all have equipment on display for up-close inspection. Hershey's will be demonstrating the Variobend trim folder in Booth 401, while Formwright will bring fully-equipped trailers with portable New Tech roll formers in Booth 309. Star 1 Products will once again demonstrate how The Star 1 Felt Applicator works in Booth 100. This simple and effective piece of equipment came on-scene a few years ago and has been popular with the roll forming community.

New to the industry is the Board & Batten Shear from Integrity Sales & Service, which manufactures the Dyna-Cut. Integrity will be demonstrating the new power shear in Booth 519.

SHOW DETAILS

Shield Wall Media recognizes that family-operated, regional metal shops comprise a significant portion of the construction roll forming industry. "We are a family focused company and as such our shows are family friendly," says Shield Wall Media Director of Shows Missy Beyer. "We learned early on that our attendees bring their families with small children and with the last Construction Rollforming Show we introduced our Rest Stop area for families. Rather than families being shuffled off to another area to wait, we include our Retreat right

Save The Date:

In 2025, the Construction Rollforming Show will be held September 30-October 1 at the Dayton Convention Center, Dayton, Ohio.



on the show floor so they can relax but still have easy access to all the action on the show floor."

Due to increasing interest and participation, Shield Wall Media has extended the Construction Rollforming Show hours. This year, the expo floor will be open from 11:30 a.m.-5:30 p.m. on Wednesday, September 18 and from 8:30 a.m.-12:30 p.m. on Thursday, September 19. To allow attendees and exhibitors to maximize their time on the expo floor, the educational session start times are limited to 8-11 a.m. Wednesday and 8-10 a.m. Thursday.

Attendee pre-registration costs just \$50 and covers every benefit the show has to offer, including access to the expo floor, entry to all educational sessions, a continental breakfast each day, and a social hour with complimentary food, beverages, and entertainment on Wednesday afternoon from 4:30-6 p.m. If you have relationships with any of the exhibitors, contact them; each exhibitor is allowed an unlimited number of free passes to share with clients.

The Show has partnered with two exceptional hotels so attendees can choose

their lodgings based on their individual needs. The Courtyard Grand Rapids Downtown is connected to the venue via a sky bridge and is a short walk to the show floor. Reserve a room online at <https://book.passkey.com/e/50857071> or call for reservations using the dedicated Group Reservations toll-free phone number to get the show rate: 1-888-236-2427.

The second official show hotel is Canopy By Hilton Grand Rapids Downtown, which is a newly built hotel in the heart of Grand Rapids. The Canopy is located just under a mile from the convention center and is located on the free Downtown Area Shuttle (DASH) line, which has a drop-off spot in front of DeVos Place. Book a room at the Canopy online at <https://bit.ly/CRFG2024> using the code **CRFG** to get the special group rate. Or you can call Canopy Reservations toll-free at 1-844-692-2667. To get the special group rate, you must tell the booking agent you are booking inside a block rate and use **Code CRFG**.

The street address of the DeVos Place convention center is 303 Monroe Ave. NW, Grand Rapids, MI 49503. Those traveling to the show should be aware there is construction in the area resulting in street closures. Until the end of September, Lyon Street will be closed, including the entrance to the DeVos Place parking garage. As a result, the parking garage should be accessed from Michigan Street.

CONCLUSION

If you form light gauge metal used in post-frame construction, metal buildings, carports, metal roofs or gutters — or you are looking to get into metal forming — you can't afford to miss the 2024 Construction Rollforming Show in Grand Rapids September 18-19.

Questions about the Construction Rollforming Show and all Shield Wall Media events can be directed to Missy Beyer, Shield Wall Media Director of Shows, at missy@shieldwallmedia.com or 920-216-3007. Learn more and watch for updates at constructionrollformingshow.com. **RF**



Outstanding Service that Never Skips a Beat.



Though SWI customers will tell you they find our machines to be among the most reliable in the industry, the occasion for scheduled maintenance and priority service calls does happen. In those instances, know that SWI proudly provides our customers with an unwavering commitment to fast, dependable service whenever the need arises. We employ strategically located, factory authorized technicians in

our fleet of fully equipped service vans throughout the four quadrants of the continental United States. Each van carries a wide inventory of parts for late model machines as well as older machines. In addition, our remote login capabilities (of which all our machines are equipped with) grant us the capacity to almost immediately assist with software updates, troubleshooting issues, aid in writing programs, and general customer service inquiries.

SWI Completes Any Metal Fab Shop:

Duplex Dual Beam Folder / Slitter



Marxman Plus & Marxman Pro



Uncoiler & Recoiler



CX5 – Auto Decoiling & Storage System



For Full Catalog or Quote: (770) 766-0880 • info@swimachinery.com • SWImachinery.com

Problem Solvers

Find These New Products At The Construction Rollforming Show

■ By Karen Knapstein



Metal Rollforming Systems coil reel.

One of the major benefits of attending trade shows is learning about the availability of new products and the challenges they help users overcome. Here are some of the new products that suppliers and manufacturers will feature at the Construction Rollforming Show September 18-19:

Attendees can get an up-close look at the Tru>Steel HD® Prints at the United Steel Supply exhibit. The Tru>Steel HD digital print line uses an inline inkjet printer, roll coater, and electron-beam curing system to produce single-sided printed steel with image resolution up to 400 dpi, which is 25% higher resolution than book and magazine publishing. Real-life items are scanned to create the most realistic digital images — which makes for metal coatings that have the genuine appearance of wood or other materials. United Steel Supply will also be showcasing Sherwin-Williams Coil Coatings' Ultra Low Gloss (ULG) 40-year SMP colors, so be sure to not miss visiting booth #300.

Metal Rollforming Systems [booth 315] will have new equipment to talk about during the show. The company reports the rotating coil reel with cart was developed at the request of numerous customers to reduce dwell time during coil change and maximize daily line throughput. By allowing a roll former line to continue to operate at full speed while simultaneously changing out and queuing up a coil for the next color run, the daily run time of a machine can be significantly increased. "With the ever-increasing cost of equipment and capital, it is important for our customers to maximize the capacity of each piece of equipment," said a company spokesperson. "Careful consideration was given to the design elements to maximize



Metal Rollforming Systems soffit line.



Insulation Dam Kit, AJ Manufacturing.

reliability and durability."

The MRS soffit line was also designed in close collaboration with many of the company's customers. "Soliciting design and feedback from customers who use, sell, and install the product was invaluable in designing a profile and machine to

WE'RE ON A ROLL

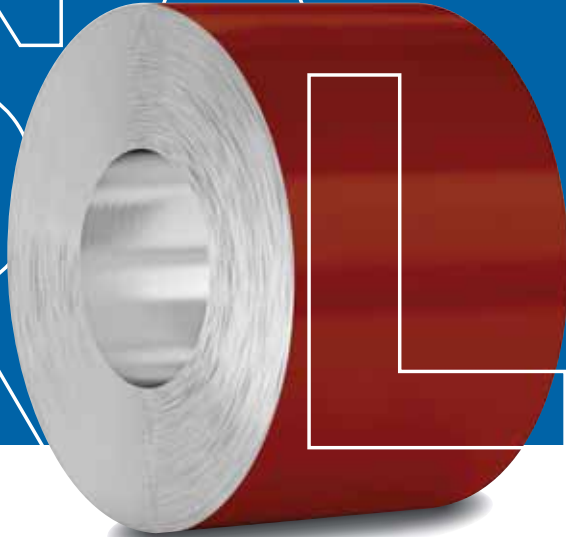

WE SPECIALIZE IN **PAINTED ALUMINUM COIL**

Like our coil, a relationship with Mid South is seamless and catered to your specifications. With over 25 years in the industry, we are painted aluminum coil experts down to our core.

Trust the specialists and let the good times roll.

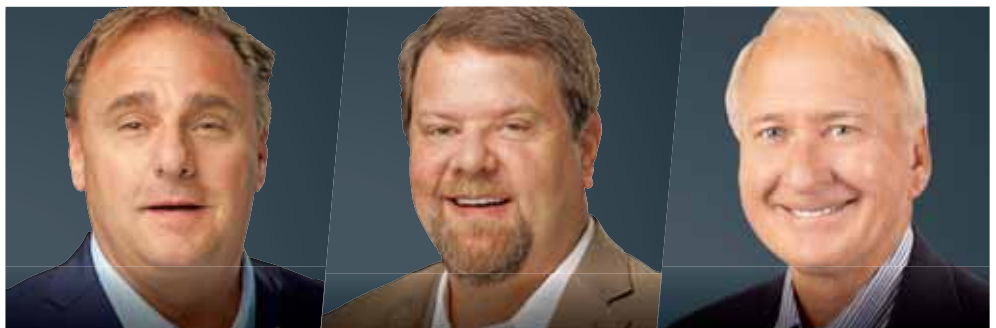

Alan Sallee Jr
Senior Vice President
731.736.4844

Courtney Friedman
Account Manager
205.292.5697

Steve Swaney
Account Manager
314.757.2733

731.664.2210
midsouthalum.com

MID SOUTH
ALUMINUM

cover the widest range of customer needs. The design utilizes industry standard coil stock of 20.125", meaning customers are able to maximize current inventory drastically reducing initial investment costs. The concealed fastener 'S lock' style lap, industry standard rib height, and a top rib flat for easy screw or nail placement, are all key features. Innovative changes over standard industry soffits include nail slots and weep holes for horizontal installation applications. Class-leading speeds over 150 feet per minute allow customers to produce more in less time."

A.J. Manufacturing [booth 623] released two products recently and both will be on display. The company is exhibiting its new insulation dam kit (patent pending). The kit is made of G-90 Galvanized 24-ga. steel and is designed to manage up to R-60 of blown cellulose or fiberglass batt insulation.

The company is also showing its new, more energy-efficient ceiling access doors, which feature a self-flashing frame fabricated of commercial-quality painted aluminum extrusions, miter cut corners, and assembled with screws. The 6"-thick door panel is designed to accommodate up to an R-42 insulation thickness, while the 4" thick door panel will accommodate up to R-28. Both are available in single and bi-fold panel designs.

Klar USA [booth 517] is exhibiting TK Ag Panels for cladding or roofing applications. The

Klar TK 9 ag panel.

company explains, "They are the best option because they reduce noise; do not rust; do not generate fungus; and protect from cold, heat and humidity." Installed as a liner, the KLAR TK 9 panels are anticorrosive and suitable for retrofitting panels with 9" between the main corrugations. The panels are recommended for use in many applications, including sheds, carports, garages, barns, calf barns, cattle shades, chicken coops, dog kennels, pole barns, hog barns, bardominiums, and car washes.

In booth 514, Integrity Sales & Service (maker of the Dyna-Cut) will be exhibiting — and demonstrating — its new electric shear made specifically for the board and batten profile. A manual shear will be available soon, but it is still in the prototype phase.

Levi's Building Components [booth 409] will be exhibiting the new CoVent Exhaust Fan Vent. Ideal for interior exhaust fans equipped with a 3" or 4" flex hose, it is an all-in-one exhaust fan vent designed for metal roofs and intended for bathroom and attic venting.

In booth 326, Northern Building Components will

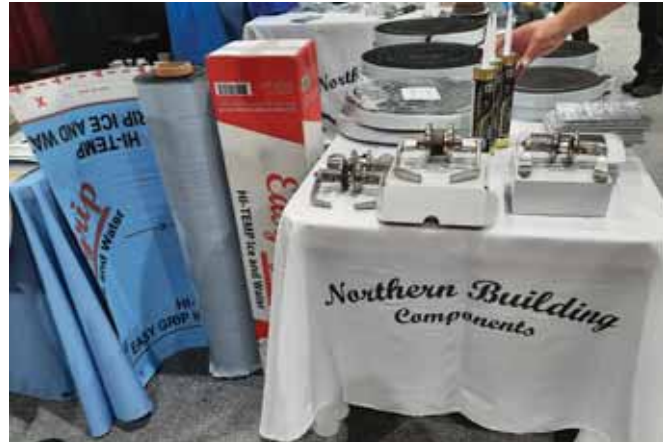

Commercial levers and knobs and Easy Grip Hi-Temp Ice and Water underlayment from Northern Building Components. The company will also exhibit composite- and steel-edged steel doors.



CoVent from Levi's Building Components.

have several new products among its offerings, including commercial levers and knobs and upgraded steel-panel doors. The company's steel-edged, steel-panel doors are both made with 24-gauge steel. Additionally, NBC has added the Easy Grip Hi-Temp Ice & Water self-adhesive underlayment to its catalog, which has "a more grippy surface" making for safer footing for roofers.

Star 1 hopes to have its newest machine — the Star 1 Folder — on display. If completed in time for the show, demonstrations of the air-over-hydraulic folder, along with the Star 1 Felt Applicator, will be held in booth 100.

Keep an eye out for these — and more — solutions to construction challenges at the Construction Rollforming Show September 18-19 in Grand Rapids, Michigan. [RF](#)

ABOVE AND BEYOND STEEL COIL

WE OFFER A VARIETY OF PRODUCTS



See how Progressive Metals can exceed your expectations!

PROGRESSIVEMETALS.COM

Call Toll Free: 855.835.9762

2024 Construction Rollforming Show

Exhibitors

Established in 2019, and produced by the publisher of Rollforming Magazine, the Construction Rollforming Show is the only trade show that is fully dedicated to the construction roll-forming industry. The exhibitors at this trade show are brought together to provide you with the information, products, and services you need to make your metal-forming business more successful.



Acu-Form

Booth #308
10550 Township Road 262
Millersburg, OH 44654
330-674-4003
330-674-4035 (fax)
wayne@acu-form.com
www.acuformequipment.com

Acu-Form has been the trusted name for premium roll-forming machines in the steel roofing industry. Our unwavering commitment to tried-and-true manufacturing processes, founded on proven design principles and strict quality control checks, sets the foundation for the Acu-Form promise — quality, reliability, and longevity. When you choose Acu-Form, you're choosing a partner dedicated to your success.



AJ Manufacturing, Inc.

Booth #623
1217 Oak St.
Bloomer, WI 54724
800-328-9448
715-568-3099 (fax)
vwachtendonk@ajdoor.com
www.ajdoor.com

A.J. Manufacturing builds high quality pre-painted or stainless steel walk doors. All doors are pre-hung in steel, aluminum or stainless steel frames with 4" x 4.5" fixed pin hinges for 4-way universal swing even with a foamed in place door lite. A.J. also offers a complete line of high quality vinyl windows. Options include horizontal sliding, fixed lite, casement, single hung, and double hung windows with the patented EZ-v™ vinyl trim and flashing system.

AkzoNobel

AkzoNobel Coil and Extrusion Coatings

Booth #319
1313 Windsor Ave.
Columbus, OH 43211
www.coilcoatings.akzonobel.com/us

Beyond Performance. It is what makes us different. Built on over 200 years of experience. Whatever we do, we achieve the highest standards. Creating products

of tested, proven and enduring quality. Working in partnership to best serve our customers. Delivering genuine added value. Protecting reputations as much as surfaces. Simply being trusted to do all this, and more, like nobody else can. Quality, Service, Trusted Partner. AkzoNobel Coil and Extrusion Coatings.



AmeriLux International

Booth #321
1300 Enterprise Drive
De Pere, WI 54115
920-336-9300
920-337-9301 (fax)
info@amerilux.com
www.amerilux.com

AmeriLux International is a value-adding distributor and fabricator of building materials and plastic sheets. Our product offering includes: CoverLite® polycarbonate corrugated panels are perfect for skylight and sidelites. Agrilite™ PVC corrugated liner panels are durable and easy to install. Abuse and moisture resistant, EZ Liner™ is a low-maintenance PVC interlocking liner panel. EZ Slatwall is a versatile wall organizations system. EZ Forms® concrete wall systems assembles easily because the forms and spacers snap together horizontally.



Ameripak, Inc.

Booth #115
2009 Button Lane
LaGrange, KY 40031
502-222-8244
502-222-0278 (fax)
customerservice@ameripak.net
www.ameripak.net

Ameripak, Inc. is the industry's leading manufacturer of metal wrapping equipment. Our heavy-duty wrapping systems are designed to withstand the everyday demands of high-speed roll forming while producing a consistent, uniform package to protect your finish goods during shipment. Ameripak, Inc. offers a variety of packaging solutions and materials from fully automatic equipment to simple manual wrappers and wrapping supplies.



CONDENSATION CONTROL WHICH INCREASES PROFITS, NOT LABOR COSTS



You can use Dripstop™ products **anywhere** where you are not heating or cooling and don't want it to rain indoors.



For more information visit
www.dripstop.com



Ask for it from your preferred roof panel supplier.
www.dripstop.com or call us at: (937) 660-6646

Scan the code for more information or to get in touch.

SHOWTIME

THE \$50
PRE-REGISTRATION
FEE FOR ADMISSION
COVERS BOTH
DAYS AS WELL AS
THE EDUCATIONAL
SEMINARS.

Punch Your TicketS to our next EVENTS!

FROM THE
PUBLISHER OF
ROLLFORMING
MAGAZINE



2024
Construction
Rollforming
Show

SEPTEMBER 18-19, 2024
DeVos Place, Grand Rapids, MI
constructionrollformingshow.com

ADMIT 1

FROM THE
PUBLISHER
OF GARAGE,
SHED &
CARPORT
BUILDER
MAGAZINE



2025
GARAGE • SHED • CARPORT
BUILDER
SHOW

JANUARY 15-16, 2025
Greenville Convention Center, Greenville, SC
garageshedcarportshow.com

ADMIT 1

FROM THE
PUBLISHER
OF FRAME
BUILDING
NEWS



2025
POST-FRAME
BUILDER SHOW

JUNE 25-26, 2025
Spooky Nook Sports Lancaster, Manheim, PA
postframebuildershow.com

ADMIT 1

For More Information Contact Missy Beyer:
missy@shieldwallmedia.com ▪ PH 920-216-3007



AMS Controls

Booth #420

12180 Prichard Farm Road
Maryland Heights, MO 63043
314-344-3144
314-344-9996 (fax)
sales@amscontrols.com
www.amscontrols.com

AMS Controls develops advanced hardware and software technologies for production management and controls that increase profitability and productivity for the metal forming industry. AMS Controls' customers include some of the largest metal processing operations including those producing metal buildings, metal roofing, light gauge framing, fenestration, custom roll formed parts, HVAC ductwork, and more. With over 14,000 installations at more than 4,500 locations worldwide, AMS Controls sets the standard for operational efficiency in the metal forming industry.



ASC Machine Tools, Inc.

Booth #512

900 North Fancher Road
Spokane, WA 99212
509-534-6600
509-536-7658 (fax)
salesupport@ascmt.com
www.ascmt.com

Established in 1949, ASC specializes in roll-forming machinery, tooling, and associated equipment utilized for metal processing. We offer a variety of panel lines, single and multi-trim roll formers, cz purlin lines, garage door and roll-up door lines, track lines, channel lines, bottom

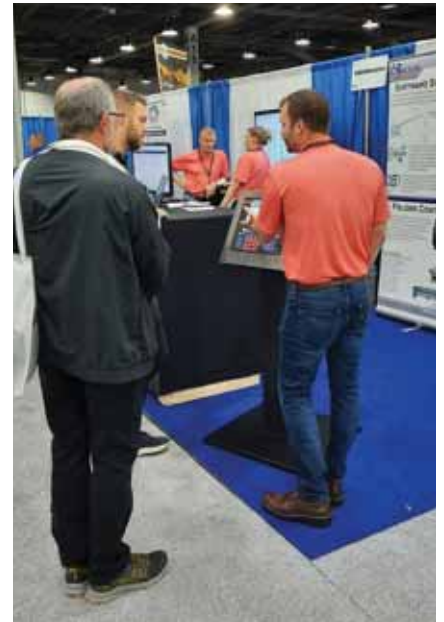

bar roll former and custom designed roll-forming lines – Made in Spokane, Washington USA!



PREMIUM QUALITY

ROLLFORMING MACHINERY

MADE IN THE USA SINCE 1949



Celebrate with us at the

Construction Rollforming Show

SEP 18 & 19, 2024

DeVos Place
Grand Rapids, MI

BOOTH 512



ASC MACHINE TOOLS, SPOKANE, WA USA



WWW.ASCMT.COM

TEL: (509) 534-6600



Beck Automation

Booth #522

814 Fee Fee Road
St. Louis, MO 63043
314-576-9736
314-227-2104 (fax)
www.beckautomation.com

Beck Automation offers complete controls systems and production management software packages for the metal forming industry. Since 2001, Beck Automation has proven to be an industry leader in this market and pride ourselves on the customer service and support in which we back our products. Whether you're looking for a way to track key indices to streamline your business, or just tired of programming jobs at the machine, we have the software solution for you. Connex is a multi-user, Enterprise office to shop production software capable of integrating with both ERP and design software packages.



BRADBURY GROUP

Bradbury Group

Booth #214

1200 E Cole St.
Moundridge, KS 67107
620-345-6394
bradbury@bradburygroup.com
www.bradburygroup.com

The companies within The Bradbury Group design and build quality roll forming equipment, cut-to-length equipment, levelers, automated production systems, metal tile roofing systems, and controls for entry level operations to full scale facilities. Whether you need a single machine or an entire manufacturing system, we have the expertise and experience to build equipment that will exceed your expectations. Our machines and systems are known for their reliability, high

production capabilities, scrap reduction, and build quality.



Capital Forest Products

Booth #427

222 Severn Ave. Bldg. 14, Ste. 100
Annapolis, MD 21403
410-280-6102
410-280-6109 (fax)
info@capitalforest.com
www.capitalforest.com

For over 40 years, Capital Forest Products has been leading the distribution of lumber and manufacturing materials for the building industry along the east coast. Exclusive relationships with our European and Canadian sawmills allows us to deliver high-quality, premium products to you in full or mixed loads. Supplying exceptional furring strips, framing lumber, panel products, and specialties to industry leaders allows us to be the prime resource that positions you leaps ahead of the competition.

These are no ordinary post frame screws

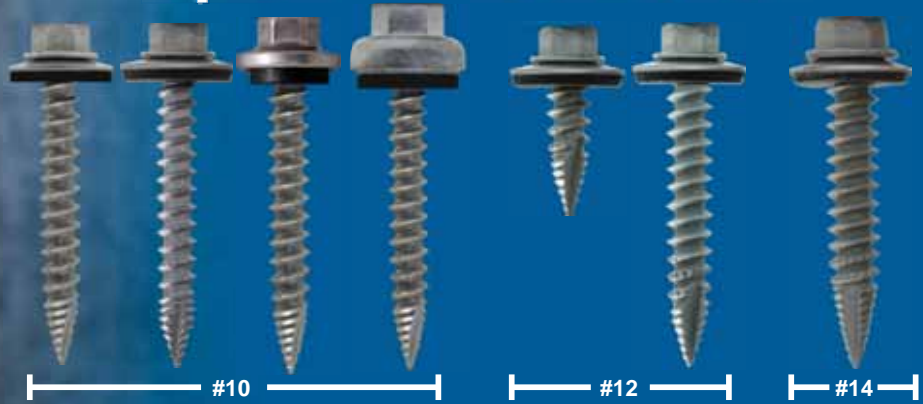

- Low-angle thread helps prevent over-driving the washer and increases resistance to back-out
- #10, #12, #14 | Steel with TRI-SEAL | Stainless Steel ZAC Zinc Cap Head | Stainless Cap Head
- Patented BURR-BUSTER® Point reduces burrs caused during piercing of the steel



Check out the performance versus ordinary screws!



Call for free samples!

We make connections better!

CIDAN MACHINERY

CIDAN Machinery Group

Booth #203

665 Hwy 74 S #350
Peachtree City, GA 30269
770-692-7230
sales-us@cidanmachinery.com
<https://cidanmachinery.com/us/>

CIDAN Machinery is a leader in sheet metal machinery manufacturing, providing innovative and efficient solutions for the metal construction and roll-forming industry. As a one-stop partner, they specialize in high-quality coil processing and sheet metal folding and forming machines, focusing on advanced technology and reliability. Since 1907, CIDAN has been dedicated to customer satisfaction and continuous improvement, shaping tomorrow's world with its cutting-edge products.

Crowntour

Crowntour

Booth #716

1245 S 250 W
LaGrange, IN 46761
260-463-5001
260-463-5004 (fax)

Crowntour is a supplier of coils, trims, and metal roofing accessories for the hidden-fastener market, offering 29 colors in 26 gauge, Grade 50 including textured, smooth and woodgrain patterns coated with AkzoNobel Ceram-a-Star 1050 paint system. We offer custom width and job lot slit coils as well as complete trim packages.

DAYSTARTM

High Performance Natural Lighting Systems

DayStar Systems LLC

Booth #624

14226 Highway 4
Campbell Hill, IL 62916
866-7DAYSTAR (732-9782)
info@daystar1.com

Daystar Natural Lighting Systems provide brilliant, even illumination regardless of building size. Also, Daystar's light-harvesting method actually extends daylight hours by collecting and dispersing more natural light during early mornings and late afternoon resulting in superior illumination. With Daystar you can have the efficiency and beauty of evenly distributed natural sunlight without the glare, extreme temperatures, or shadows of direct sunlight. Daystar's insulated curb, lightshaft, and lens provide 40-50% better thermal value than conventional skylight designs.

BRADBURY GROUP



BRADBURY EQUIPMENT DRIVES GROWTH.



Direct Metals Inc.

Booth #224

1719 Baseline Court
Fort Myers, FL 33905
855-800-8878
239-599-8545 (fax)
orders@directmetalsinc.com
www.directmetalsinc.com

Direct Metals Inc. designs and supplies fasteners, panel clips and many accessories for metal, low slope and shingle roofing. Primary products include long-life Dade County code-compliant SCAMP 304 SS Cap metal-to-wood fasteners as well the popular PANCLIP brand of Pancake head screws and panel clips for standing seam metal roofs. Additional products include drains, pipe flashings, butyl tape, foam rolls and closures, Ridgevent, 304 SS rivets, windows, reflective insulation, and polycarbonate panels for skylights. OEM manufacturer, dealer and distributor sales only.



Freudenberg Performance Materials LP

Booth #213

3500 Industrial Dr.
Durham, NC 27704
503-871-5806
info@dripstop.com
www.dripstop.com

For over 25 years, Dripstop™ has been the absolute best way of dealing with condensation on non-insulated metal roofs. It has been tried and tested in every climate condition across the globe and has proven to be a simpler and more economical way. The membrane will absorb the water caused by condensation, thus preventing dripping from the roof. Dripstop™ serves as an added layer of protection for the metal in corrosive environments while also improving inside and outside acoustic properties.



DutchTech, Inc.

Dutch Tech Industries

Booth #325

107 E 3rd Ave.
Lobelville, TN 37097
931-325-0000
office@dutchtechindustries.com
www.dutchtechindustries.com

We are proud to be an American owned and operated manufacturer located in Middle Tennessee. Dutch Tech's ThermoGuard is America's new favorite reflective thermal insulation. With a super strong woven backing that's nearly impossible to tear, ThermoGuard's premium strength sets it apart from the competition. A 3mm foam core gives it thermal resistance to insulate your building while the reflective metalized face reflects radiant heat keeping your building comfortable in the summer and in the winter.



SUPPLIED WITH EXCELLENCE

We provide high-quality flat-rolled steel, stainless steel, and aluminum paired with the easiest experience.

Learn more by visiting us at
Booth #101





**Dyna-Cut / Integrity
Sales & Service**

Booth # 519
4512 Industrial Dr.
Millington, MI 48746
989-522-5044
sales@integrity-sales.us
www.Dyna-Cut.com

We at Dyna-Cut are committed to quality. Our power shears have multiple power options: electric, air, line shaft, or gas engine. The blades are designed to match the profile of your roll former. Now offering a new Board & Batten/Standing Seam shear. Our HRB 36 shear is our contractor shear. It will make fast quality cuts on the job. Our shears are designed with you in mind.

**DYNAMIC
FASTENER**

Dynamic Fastener

Booth #417
9911 East 53rd Street
Raytown, MO 64133
800-821-5448
www.dynamicfastener.com

Offers same-day shipping of screws, anchors, flashings, safety equipment, hand tools and power tools. In-house painting of screws and rivets, with one or two-day lead time. Dyna-Guard snow retention system for metal roofs. Dyna-Clamps are available to accommodate many profiles of standing seam roofs. The company's free 140-page, full color tool and fastener handguide provides engineering data and also details product offerings.

FORMTEK

a Mestek company

Formtek

Booth # 122
4899 Commerce Pkwy.
Cleveland, OH 44128
216-292-4600
sales@formtekgroup.com
www.formtekgroup.com

Formtek is a group of established equipment manufacturing brands, each providing innovative and reliable equipment for metal forming and processing industries. Formtek combines the "best of class" technology and equipment into integrated manufacturing systems that improve productivity. Formtek's brands work together to design, build, and service automated metal forming and fabricating systems. Whether it's completely new equipment or an upgrade and refurbishment of existing machinery, Formtek's solution can be developed to meet your objectives.



Panel Rollformers

Titan, Signature & Patriot

Trim Rollformers

Single & Multi Profiles

Slitting Lines

Stand Alone, Cut to Length, & Slit to Recoil

Decoilers, Upenders, Shears

and much more!

**Industry Leading Quality
Unrivalled Service**



A 30 YEAR
HERITAGE



7x WINNER



888.284.6794 | www.mrsrollform.com
info@mrsrollform.com
4511 N Freya St. | Spokane, WA 99217





Formwright

Booth #309
1195 S 250 W
LaGrange, IN 46761
260-463-4010
260-463-4011 (fax)

Formwright is the Midwest's leading dealer for NewTech Machinery (NTM) standing seam roll-forming machines. We specialize in complete package setups, which include machines, custom trailers, and all the tools and accessories needed for the ultimate metal roofing outfit. Our expertise focuses on the SSQII Multi-Pro, SSR Multi-Pro Jr, and Mach II Gutter machines, offering up to sixteen unique profiles for both commercial and residential needs. Our heavy-duty trailers are specifically designed for the roll-forming industry and NTM machines. In addition to equipment, we provide phone support and on-site service, ensuring your operation runs smoothly. Formwright is your partner for superior products and best in class service.



Gage Bontrager Consulting

Booth #109
1794 480th St. SW
Kalona, IA 52247
319-330-8155
gagebontragerconsulting.com

If you are a business owner or are in a leadership position and find yourself in a situation where your business is running you instead of you running your business, we are here to help alleviate that stress while helping you grow. GBC offers one-on-one coaching and peer groups to guide in leadership development, sales training, human resources assistance, personal development, and developing your company culture to put you on a path towards success.



Garage, Shed & Carport Builder Show

PO Box 255
Iola, WI 54945
920-216-3007
missy@shieldwallmedia.com
GarageShedCarportShow.com

The Garage, Shed & Carport Builder Show, to be held January 15-16, 2025, at the Greenville Convention Center, Greenville, South Carolina, brings suppliers and manufacturers together for the convenience of shed, garage and carport builders. During this event, more than 50 exhibitors will fill the 15,000 square foot show floor. Make your plans today to exhibit or attend. For more information contact Shield Wall Media Show Director Missy Beyer at missy@shieldwallmedia.com or 920-216-3007.

IF YOU ROLL FORM METAL, SMARTBUILD SYSTEMS IS THE SOFTWARE SOLUTION FOR ALL YOUR MARKETS



SmartBuild for Post Frame Structures and All-Metal Buildings

SmartBuild for Post Frame will automatically generate a full set of drawings, a complete material list, labor estimates, pricing and a sales contract. All in about 15 minutes. Or, put SmartBuild on your website and let your visitors "design their own."

SmartBuild now supports post-frame, all-metal buildings, and metal roofing. Use SmartBuild directly with customers for real time design!





Global Film Source

Booth # 119
 518-7 Old Post Road #297
 Edison, NJ 08817
 800-308-0842
 732-442-3888 (fax)
 admin@filmsrc.com
 www.filmsrc.com

Global Film Source is a US-based manufacturer of protective film with production facilities in Scranton, Pennsylvania, and Stockton, California, and a distribution location in Miami, Florida. They produce surface protection films for any application, including frosted or "crinkle" coatings and embossed metal surfaces. Their solutions include proprietary "beaded" adhesive systems, and fully recyclable glueless technology. GFS also produces adhesive tapes, including masking, strapping, filament and duct tape. They offer superior quality, attractive pricing, and short lead-times.



Graber Post Buildings, Inc.

Booth #220
 7716 N 900 E
 Montgomery, IN 47558
 800-264-5013
 info@graberpost.com
 www.graberpost.com

Graber Post Buildings is a leading distributor and manufacturer of post-frame and metal roofing supplies and materials. We roll-form 6 different metal panels, and we have a custom trim department that can produce almost any trim profile needed for your projects. We also produce nail-laminated columns and pre-engineered wood trusses up to 100' clear span. We also stock overhead doors, windows, sliding door components, cupolas, fasteners, underlayments, vapor barriers, insulation, and much more. A true 1-stop shop!



Hershey's Metal Meister

Booth #501
 420 Progress Dr.
 Mattoon, IL 61938
 217-234-4700
 info@variobendusa.com
 www.hersheysmm.com

Hershey's Metal Meister is a company dedicated to supplying top notch machinery along with unmatched service! Our Variobend trim folders have become a staple in the trim industry. Our goal is to assist our customers to deliver quality products to the communities they serve.



MINI-DRILLER™
 AVAILABLE



MINI-DRILLER™
 AVAILABLE



MINI-DRILLER™
 AVAILABLE



REQUEST A SAMPLE OR BECOME A SUPPLIER (877) 438-1017



Hixwood

Booth # 116

N14685 Copenhaver Ave.
Stanley, WI 54768
715-644-0765
715-644-0094 (fax)
www.hixwood.com

Hixwood.... Quality you can count on! Since its inception in 1998, Hixwood has focused on providing premium quality building products to the post-frame, commercial and residential industries. Our offerings include coil, blank flat stock, and custom slit coil. Available in 36+ colors.



Klar USA

Booth #517

sales@klar.us.com
www.klar.us.com

Manufacturer of rigid PVC panels for ag building applications. Klar uses the most advanced co-extrusion multilayer technology, which provides excellent resistance to impact and thermo-acoustic insulation properties. Our panels were designed to resist high levels of corrosion from chemicals, humidity, and micro-biologicals, so they will never rust or rot. Ideal for animal confinements, farms and barns (livestock, poultry, hogs, etc.), garages, carwash facilities, storage units (hay, fertilizers, machinery), sheds, shelters, chicken coops and similar uses.



Lakeside Construction Fasteners, Inc.

Booth #314

6476 Highway 135 North
Paragould, AR 72450
800-537-4160
sales@lakeside-fasteners.com
www.lakeside-fasteners.com

Lakeside Construction Fasteners, Inc. is a U.S.-owned and operated, full service, international fastener supplier and manufacturing company offering a vast array of construction fasteners, pipe flashing and foam alternative solutions. From total supply chain management to total project management, coupled with U.S.-based warehousing and sourcing of product from the Pacific Rim — Lakeside will provide a custom construction fastener or pipe flashing solution for your organization.



DURABLE, HIGH-QUALITY ROOFING



At Hixwood, you'll find a huge inventory of heavy-gauge steel products for residential, ag or commercial roofing projects. Choose from Snap-Lock, Residential Rib 6", Super-Rib 9" and Commercial PBR 12" panels and a wide array of smooth and textured colors — plus 12 specialty finishes. Available in 24, 26, 28, and 29 ga.

Call today or visit us online for all your roofing needs.



715-644-0765 | HIXWOOD.COM



Manufacturer Of Metal Roll Forming Equipment

ABOUT US

Meet the growing customer demand for steel roof materials with an efficient, automated system that's ready to work when it hits the production floor.

OUR SERVICES

- » Versatile Growth Options
- » Shipping & Installation Available
- » Customer Support
- » Power Options
- » Pre-Tested Machines
- » Acu-Form Thru-Hardened D2 Steel



COME SEE US

Sept. 18-19, 2024



Contact For More Info ↓

10850 County Road 320
Millersburg, OH 44654

P: (330) 674-4403
F: (330) 674-4035

wayne@acu-form.com
acuformequipment.com

5TH ANNUAL Construction Rollforming Show

September 18-19, 2024

DeVos Place, Convention Center
Grand Rapids, MI

FOR MORE INFORMATION
CONTACT MISSY BEYER:
missy@shieldwallmedia.com
920-216-3007



REGISTER BELOW OR ONLINE: www.constructionrollformingshow.com

5TH ANNUAL CONSTRUCTION ROLLFORMING SHOW

Please fill out and mail with payment by September 1st to: CRS Registration, P.O. Box 255, Iola, WI 54945.

(Please Print)

Name(s): _____

Company: _____

Address: _____

City/State/Zip: _____

Phone (required): _____

Email: _____

ADMISSION FEE:
\$50.00

Quantity: _____

Total Enclosed: _____



Levi's Building Components

Booth #409

400 Burkholder Drive
Ephrata, PA 17522
877-897-7020

info@levisbuildingcomponents.com
www.levisbuildingcomponents.com

Renowned for delivering top-tier products, expedited shipping, and meticulous order fulfillment, Levi's Building Components stands as a premier wholesale supplier, offering a comprehensive solution for all your metal roofing requirements. We offer a diverse range of fasteners, including FastGrip, MetalGrip, ProCap and ProZ. Additionally, we have an extensive selection of snow retention guards in our Snow Defender line, available in over 40 colors. Roofing accessories include, but are not limited to, roofing underlayment, venting solutions, sealants, and more, featuring our exclusive FastVent Plus, FloVent, and Roloshield lines. For added convenience, our website includes a user-friendly Snow Defender Calculator, optimized for mobile devices.



Liberty Painted Products

Booth #518

760 Boardman Canfield Road, Ste 1
Youngstown, OH 44512
330-967-2896

330-649-2652 (fax)
info@libertypainted.com
www.libertypainted.com

Liberty Painted Products is a distributor of bare and prepainted steel coils for the metal roofing and metal building industries. We offer a full range of bare and prepainted Galvalume in various thicknesses and widths to service the market. We stock industry standard sizes and paint systems but also offer custom stocking programs to meet our customers' needs. Our goal is to provide our customers with industry-leading customer service and know-how while supplying them with high-quality, competitively priced products.



Little Harveys

Booth #525

4708 Hunting Creek Church Road
Hamptonville, NC 27020

Contact: Jesse Schlabach
800-202-8831
336-468-4309 (fax)
4309@emailbyfax.com

Little Harveys is a distributor of specialty steel coils.



Lumbermen Associates

Booth #123

2101 Hunter Road
Bristol, PA 19007-0720
800-363-0062
215-785-4600 (fax)

info@lumbermenassoc.com
www.lumbermenassoc.com

Lumbermen Associates (LA) is a wholesale distributor of lumber and plywood that services all sectors of the industrial market from our two locations in Bristol, Pennsylvania, and Crewe, Virginia. This includes companies that specialize in packaging and crating and require HT and HTDUN stamped material. Lumbermen's inventories a large array of various grades and species of lumber in softwoods and hardwoods. LA also stocks panels ranging from OSB to Pine and Fir plywoods. LA mills orders to customers' exact specifications for custom and stock requirements.



Marion Manufacturing, Inc.

Booth #625

201 S. Coble
Marion, KS 66861
620-382-3751
620-382-2322 (fax)

sales@marionmanufacturing.com
www.marionmanufacturing.com

At Marion Manufacturing, we add the value to the metal! We design, fabricate, and install custom manufacturing and production machinery. We specialize in metal-forming equipment such as: roll formers, uncoilers, shears, stackers, etc. Marion Manufacturing also offers a full-service machine shop and re-tooling/service on other brands of equipment.



Metal Rollforming Systems

Booth #300

4511 North Freya St.
Spokane, WA 99217
509-466-6854
888-284-6794
www.mrsrollform.com

MRS designs and manufactures industry leading roll-forming equipment 100% in-house. Metal Rollforming Systems aims to be your 'one-stop shop' for all your roll-forming needs, allowing customers to save time and money when purchasing roll-forming equipment. Along with our complete panel lines, we specialize in custom trim profiles with all the needed accessories to complete your metal panel needs. From start to finish, Metal Rollforming Systems is your trusted partner since 1993.





METALFORMING

MetalForming, LLC

Booth #419

100 International Dr.
Peachtree City, GA 30269
678-325-2313
770-631-7776 (fax)
info@metalforming-usa.net
www.metalforming-usa.com

MetalForming is your One Partner / Trusted Expert in metal building and architectural sheet metal technology with over 25 years of selling and servicing high quality metal folders, shears, roll formers, slitters and curvers from the most respected manufacturers across the globe. We have the largest service and parts organization in the business. Schleich Quadro is the number one bestselling portable roll-forming system in the world offering 11 profiles with instant change over.



Mill Steel Company

Booth #101

2905 Lucerne Drive SE
Grand Rapids, MI 49546
800-247-6455
616-977-9411 (fax)
info@millsteel.com
www.millsteel.com

Mill Steel Co. is a leading steel and aluminum distributor in North America, based in Grand Rapids, Michigan, with six Regional Processing & Distribution Centers. Serving demanding industries, they prioritize superior quality, delivery, and performance. Their knowledgeable staff, advanced coating systems, and easy online ordering cater to your needs. Available products include 24-, 26-, and 29-gauge SMP, Sherwin-Williams WeatherXL, AkzoNobel, polyesters, and custom color codes.



NC Automation

Booth #622

746 US 250 N
Ashland, OH 44805
888-688-1041
neil@ncautomation.com
ncautomation.com

Are you struggling to keep track of orders and inventory? With QB Metal Shop software you can get on with the real work of running your facility and let the software keep track of your products and help you stay organized. From the online portal than enables your customers to enter their own orders and design custom trims to the integration with your equipment, QBMS is designed to save you time and keep you and your customers in the know.



THE BEST WAY TO INSULATE





- Blocks 96% of radiant heat transfer
- Class 1/A Fire-Rated
- Prevents interior condensation
- Unaffected by humidity
- UV resistant





- Metal roofing
- Pre-engineered steel buildings

- Garages & carports
- Pole barns & agricultural buildings

- Post frame buildings

Contact us for more information

888-887-3645 www.rFOIL.com



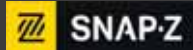

Install Your Metal Ridge Vent

FASTER THAN EVER

- ✓ PRE-CUT LENGTHS
- ✓ PRE-PUNCHED FASTENERS
- ✓ PRE-APPLIED BUTYL TAPE

CALL US!

(717) 572-0910





Northern Building Components

Booth #326
44815 CR 388
Bloomington, MI 49026
269-521-4554 ext. 1

Northern Building Components (NBC) is a manufacturer/distributor of post-frame building components. We provide US and Canadian based customers with great customer service and quality items including ridge vents, premium closures, reflective insulation, pipe flashing, Em-seal products, snow guards, sealants, fasteners, metal-to-wood/roofing screws, entry doors, and other miscellaneous items for post-frame buildings. We also offer polycarbonate panels and ridge caps, EZ Grip underlayment, and Magnum lag screws. We have 24-gauge painted steel doors with composite edge on panels. Plus, we have cupolas in 23 colors and 3 sizes in stock and ready to ship; we also offer cupolas with windows.



Paragon Computing Solutions

Booth #221
20 S Reamstown Road
Stevens, PA 17578
866-971-0940
sales@goparagon.com
www.goparagon.com

Experience Paradigm ERP, a streamlined management system that allows you to seamlessly manage inventory, manufacturing, delivery, and accounting for your roll-forming business. The system can be further extended with integrations to popular control software and building design packages, providing an integrated, paperless process flow throughout the complete design, order, production, and delivery lifecycle of an order.



Plyco Corporation / East Coast Fasteners

Booth #226
500 Industrial Drive
Elkhart Lake, WI 53020
800-558-5895
marketing@plyco.com
www.plyco.com

For over 70 years, Plyco has been a leading supplier of products to the post-frame, metal clad building and commercial construction industries. Providing metal doors, windows, horse stall systems, ventilation products, reflective insulation, fasteners and closures, and more.



Progressive Metals

Progressive Metals

Booth #201
PO Box 685
Cornwall, PA 17016
855-835-9762
www.progressivemetals.com

Progressive Metals aims to meet and exceed all customer coil needs. Offering a wide variety of colors in high-quality 28-gauge coil and 26- and 24-gauge slit coil, excellent customer service, and exceptional delivery across the United States. We also offer a full line of accessories to finish your build.



Red Dot Products

Booth #413
465 N Reading Road
Ephrata, PA 17522
833-473-3368
717-740-6644 (fax)
www.reddotproducts.com

Most rollformers, metal distributors, and building supply companies are limited by their inventory space and can't hold everything their customers ask for. We use our purchasing power and warehouse space to provide you with competitive pricing and fast shipping for coils, fasteners, snow retention, color-matched accessories, and more.



rFOIL Reflective Insulation

Booth #108
279 Humberline Dr.
Etobicoke, ON M9W 5T6
Canada
800-837-8961
www.rFOIL.com

rFOIL Reflective Insulation is the leading manufacturer of reflective insulation to the post-frame, metal building and metal roofing industries. rFOIL is specially designed to reduce radiant heat gain/loss and eliminate condensation in metal buildings. rFOIL utilizes a metalized aluminum surface(s) for outstanding thermal resistance, and an inner core of high-strength bubble to reduce condensation. rFOIL's white interior facing contains UV inhibitors and antioxidant additives for long-term durability and resistance to cracking or flaking. rFOIL products are RIMA-Verified and tested to the highest ASTM standards.

Rollforming Magazine

Rollforming Magazine

PO Box 255
Iola, WI 54945
715-252-6360 (advertising)
715-513-6767 (editorial)
subs@shieldwallmedia.com
(subscriptions)
karen@shieldwallmedia.com
(editorial)
www.rollformingmagazine.com

Published six times per year, Rollforming Magazine provides professional users of construction roll-forming equipment access to information about the industry: best practices, safety, technical information, available products, and more.



SHERWIN-WILLIAMS.
Coil Coatings

Sherwin-Williams Coil Coatings

Booth # 111
888-306-2645
coilhelp@sherwin.com
www.coil.sherwin.com

Sherwin-Williams has been a leader in the art and science of metal coatings that excel in both beauty and function. High-quality, field-proven options including Fluropon®, a 70% PVDF, and WeatherXL™, an SMP coating, each known for its time-tested reliability. Each coating comes to life through a full palette of colors and textures to meet the most demanding environmental requirements and designs. We provide protection against weathering and damage that allows your project to endure.



Shield Wall Media

PO Box 255
Iola, WI 54945
715-252-6360 (publisher)
subs@shieldwallmedia.com
www.shieldwallmedia.com

Shield Wall Media publishes Rollforming Magazine and produces the Construction Rollforming Show. Visit the booth for free subscriptions to each of the company's expanding line of titles, including Rollforming Magazine, Frame Building News, Metal Roofing Magazine, Rural Builder, Roofing Elements, Metal Builder, and Garage, Shed & Carport Builder.

COIL UPENDER

5-TON - ELECTRIC MODEL

1. BALANCED DESIGN
2. NO MORE DAMAGED COILS!
3. HEAVY DUTY DRIVE SYSTEM
4. 5-TON CAPACITY
5. DESIGNED TO DO THE WORK GENTLY
6. HYDRAULIC MODEL AVAILABLE
7. LOAD COIL FROM END OR SIDE
8. COMPACT SIZE: 50" X 64" (FOOTPRINT)

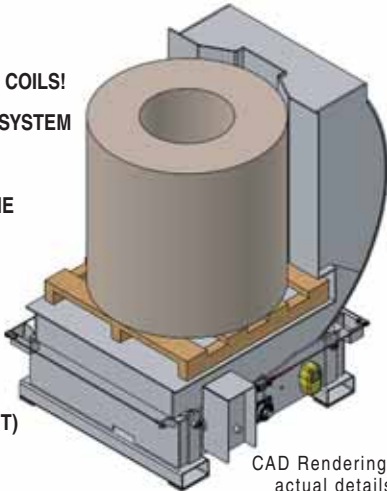

CAD Rendering, actual details may vary.



CALL NOW FOR A FREE BROCHURE

STOLLMETALWORKS

SOLOMON STOLL - JOEL LESHER
6600 BACK LANE WAYNSBORO, PA 17268
PHONE: **717-387-5572**

SET SCREW ALTERNATIVE

ACE CLAMP[®]
Innovative Roofing Solutions™

SNOW GUARD & SOLAR MOUNTING SOLUTIONS



No set screws

Clamps arrive assembled
Patented push-pin design, non-penetrating
Installs in half the time of other clamps

ORDERS:

860-773-4144

www.AceClamp.com





Silvercraft, LLC

Booth # 113

11903 CR 30

Goshen, IN 46528

574-825-8757

doororders@silvercraftllc.com

Tired of assembling Dutch doors on the job site? Silvercraft is the home of pre-assembled aluminum Dutch and sliding doors. Just take it off the skid, and it's ready to install. Fasten the D-latch (pre-drilled) and safety hook. Done. These premium doors are available for any equine facility or hobby building. Fully-welded aluminum frames are powder coated for long life. Flat steel sheets are available to match most metal colors. Needing light in the barn? We have doors with tempered glass tops to allow natural light into your barn.



SmartBuild Systems

Booth # 208

PO Box 20627

Boulder, CO 80308

303-579-6277

303-443-8033 (fax)

sales@keymark.com

www.smartbuildsystems.com

Now supporting full barndominium design in under 30 minutes, SmartBuild is the construction industry's only complete design system for pole buildings, all metal buildings and roofing. This simple, web-based software quickly generates a 3D model, materials list, pricing, proposals, and construction documents for almost any building structure or roof. If you supply the post frame or metal building industry, we can show you why SmartBuild is the marketing tool for cementing your relationship with these customers.



Snap-Z

Booth # 506

22 Windmill View Circle

Great Falls, MT 59404

717-572-0910

info@standingseamroofvent.com

https://snapzvent.com

Most standing seam ridge vents are too complicated to install. With SNAP-Z, installation is easy, and you can relax knowing that it won't fail over the lifetime of the roof and will vent adequately, in turn giving you satisfied customers and no call-backs. SNAP-Z has undergone rigorous testing by independent labs to ensure its standing seam ridge vent will withstand the worst elements and maintain the beautiful hidden fastener look that everyone wants. SNAP-Z currently supports 1", 1-1/2", 1-3/4", and 2" profiles. Custom design also available. "Do It Right."



Speedlap LLC

Booth # 219

21868 Driftwood Blvd.

Bloomfield, IA 52537

888-752-7552

sales@speedlap.com

www.Speedlap.com

Speedlap sets the standard as the premier cut-to-order steel soffit manufacturer and wholesale supplier to the roll forming industry. Steel soffit panels are our only product, and we guarantee a quality product with a quick turnaround. Ensuring that in the end we help create Happy Jobsites!



ST Fastening Systems

Booth # 320

6357 Reynolds Road

Tyler, TX 75708

800-352-4864

800-352-3940 (fax)

www.stfasteningsystems.com

ST Fastening Systems manufactures steel-frame and post-frame fasteners for agricultural, industrial, commercial, and residential metal roof and sidewall applications. Product strengths are drill point quality and corrosion resistance, as shown by the WOODBINDER MB drill point and ZXL zinc aluminum alloy molded head. Both products are enhanced by a powder coating paint

system. Solid and vented closure strip systems, pipe flashings, and other accessories round out the product line.



Star 1 Products LLC

Booth # 100

3394 W. Geers Road

McBain, MI 49657

888-96-STAR1

231-825-0163

231-825-0164 (fax)

With the felt industry continually growing, Star 1 Products knows the industry deserves a simple, hassle-free felt application process that eliminates the frustrations associated with felt application. The Star 1 Felt Applicator makes your felt application a breeze, designed from an operator's viewpoint to have everything user friendly and efficient. The splicing feature eliminates virtually all waste in metal and felt ... saving you money on every job. Star 1 Products also provides solutions for handling long metal packs, coil handling, and coil storage. Our goal is to make the roll former's life easier.



SteelGrip SAMP, Inc.

Booth # 520

103 First Street, Ste. S

Elk Rapids, MI 49629

231-944-0109

Admin@SteelGripSAMP.com

www.SteelGripSAMP.com

If you've got the grit to work on a steel roof, you need the grip to keep you there. Rugged SteelGrip SAMP®, Safety Assist Magnetic Mats are the answer. First tool of its kind in the industry; light weight and easy to use; provides safer footing in rain, pollen, and dew; built for long-term use on steel roofing. Step with confidence, save time and money. Improve safety. SAMP: Dedicated to Preventing Injuries and Saving Lives®.

2024 CONSTRUCTION ROLLFORMING SHOW

Grand Rapids, MI • September 18-19, 2024



330-674-4003

www.acuformequipment.com

BOOTH #308



620-345-6394

www.bradburygroup.com

BOOTH #214



509-534-6600

www.ascmt.com

BOOTH #512



888-284-6794

www.mrsrollform.com

BOOTH #300



217-234-4700

www.hersheysmm.com

BOOTH #501



618-426-1868

www.daystarskylightsystem.com

BOOTH #624



800-264-5013

www.graberpost.com

BOOTH #220



888-308-7858

www.wildcatcompany.com

BOOTH #619



833-473-3368

www.reddotproducts.com

BOOTH #413



800-202-8831

4309@emailbyfax.com

BOOTH #525



708-482-1800

<https://thlemont.com>

BOOTH #421



715-644-0765

www.hixwood.com

BOOTH #116

2024 CONSTRUCTION ROLLFORMING SHOW

Grand Rapids, MI • September 18-19, 2024

124	127	226 Plyco	225	326 Northern Building Components	325 Dutch Tech Industries	427 Capital Forest Products	528	525 Little Harveys	626
122 FormTek	123 Lumberman Associates	224 Direct Metals	221 Paragon Computing	320 ST Fastening Systems	321 AmeriLux Int.	422 County Line Concepts/TTT	425 Thomas Machinery Manufacturing Co. Ltd.	624 DayStar Systems	
116 Hixwood	121	220 Graber Post	219 Speed Lap		319 Akzo Nobel	420 AMS Controls	421 T&H Lemont	522 Beck Automation	519 Dyna-Cut/ Integrity Sales & Service
114	119 Global Film Source		213 DripStop	313 Toolcrest LLC			419 Metal-forming	520 Steel Grip SAMP	622 NC Automation
108 rFoil	115 Ameripak	214 Bradbury Group	418 Lakeside Construction Fasteners				417 Dynamic Fastener	518 Liberty Steel Products	620 Triangle Fastener
114	113 Silvercraft		209 Stoil Metal Works	309 Formwright			413 Red Dot Products, LLC	512 ASC Machine Tools, Inc	616 Strong Wall Columns
100 Star 1	111 Sherwin-Williams CC	208 Smart Build Systems	308 Acu-Form				409 Levi's Building Components	506 Snap-Z	Hershey's M
	109 Gage Bontrager Consulting		203 CIDAN	301 SWI Machinery					
	101 Mill Steel		201 Progressive Metals				401 United Steel Supply		
			300 Metal Rollforming Systems						
REST STOP RETREAT				ENTRANCE					SOCIAL HOUR

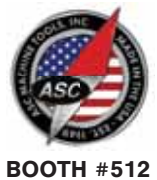
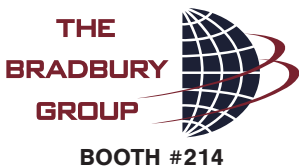

SHOW HOURS

Wednesday, September 18, 2024

Educational Sessions: 8:00am to 12:00pm

Exhibit Hall Hours: 11:30am to 5:30pm

Thursday, September 19, 2024

Educational Sessions: 8:00am to 10:00am

Exhibit Hall Hours: 8:30am to 12:30pm

625 Marion Mfg	726
623 AJ Mfg	

619 Wildcat	722
	720
615 Van Mark	716 Crown tour

501 Metal Meister, LLC

--

EXHIBITORS

Company Name	Booth #	Company Name	Booth #
Acu-Form	308	Marion Manufacturing, Inc.	625
AJ Manufacturing, Inc.	623	Metal Rollforming Systems	300
AkzoNobel Coil & Extrusion Coatings	319	MetalForming, LLC.	419
AmeriLux International.....	321	Mill Steel Company.....	101
Ameripack Inc.....	115	NC Automation	622
AMS Controls	420	Northern Building Components	326
ASC Machine Tools, Inc.	512	Paragon Computing Solutions, LLC.	221
Beck Automation	522	Plyco Corporation	226
Bradbury Group.....	214	Progressive Metals	201
Capital Forest Products	427	Red Dot Products, LLC.	413
CIDAN Machinery Group.....	203	rFoil Reflective Insulation.....	108
Crowntour	716	Sherwin-Williams Coil Coatings.....	111
DayStar Systems LLC.....	624	Silvercraft, LLC.	113
Direct Metals Inc.	224	SmartBuild Systems	208
Dripstop™.....	213	Snap-Z.....	506
Dutch Tech Industries	325	Speedlap LLC	219
Dyna Cut / Integrity Sales & Service	519	ST Fastening Systems.....	320
Dynamic Fastener.....	417	Star 1	100
Formtek	122	SteelGrip SAMM, Inc.	520
Formwright.....	309	Stoll Metal Works.....	209
Gage Bontrager Consulting.....	109	StrongWall Columns.....	616
Global Film Source	119	SWI Machinery	301
Grabber Post Buildings, Inc.	220	T&H Lemont, Inc.	421
Hershey's Metal Meister	501	Thomas Machinery Manufacturing Co. Ltd.	425
Hixwood	116	Toolcrest LLC.....	313
Klar USA.....	517	Tough Trade Tools by County Line Concepts LLC	422
Lakeside Construction Fasteners, Inc.	314	Triangle Fastener Corp	620
Levi's Building Components	409	Unist, Inc.	515
Liberty Painted Products	518	United Steel Supply	401
Little Harveys.....	525	Van Mark Products Inc.	615
Lumbermen Associates	123	Wildcat, LLC.	619

KEEP UP TO DATE BY VISITING:

www.constructionrollformingshow.com

Exhibitors and/or booth locations are also subject to change due to unforeseen circumstances.



BOOTH #116



BOOTH #413



BOOTH #619



BOOTH #525



BOOTH #220

THANK-YOU

2024 CONSTRUCTION ROLLFORMING SHOW SUPPORTERS



BOOTH #100



METALFORMING

BOOTH #419



BRADBURY
GROUP

BOOTH #214



BOOTH #413



Wildcat
Fasteners

BOOTH #619



BOOTH #625



BOOTH #220

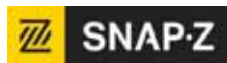

BOOTH #506



BOOTH #308



BOOTH #401



BOOTH #417



BOOTH #101



BOOTH #525



BOOTH #208



BOOTH #620



BOOTH #116



BOOTH #409



BOOTH #213



BOOTH #301



BOOTH #421



BOOTH #203



BOOTH #321



BOOTH #319



BOOTH #108



BOOTH #224



BOOTH #623



BOOTH #401



BOOTH #512



BOOTH #300



Progressive Metals

BOOTH #201

VISIT THEM IN GRAND RAPIDS

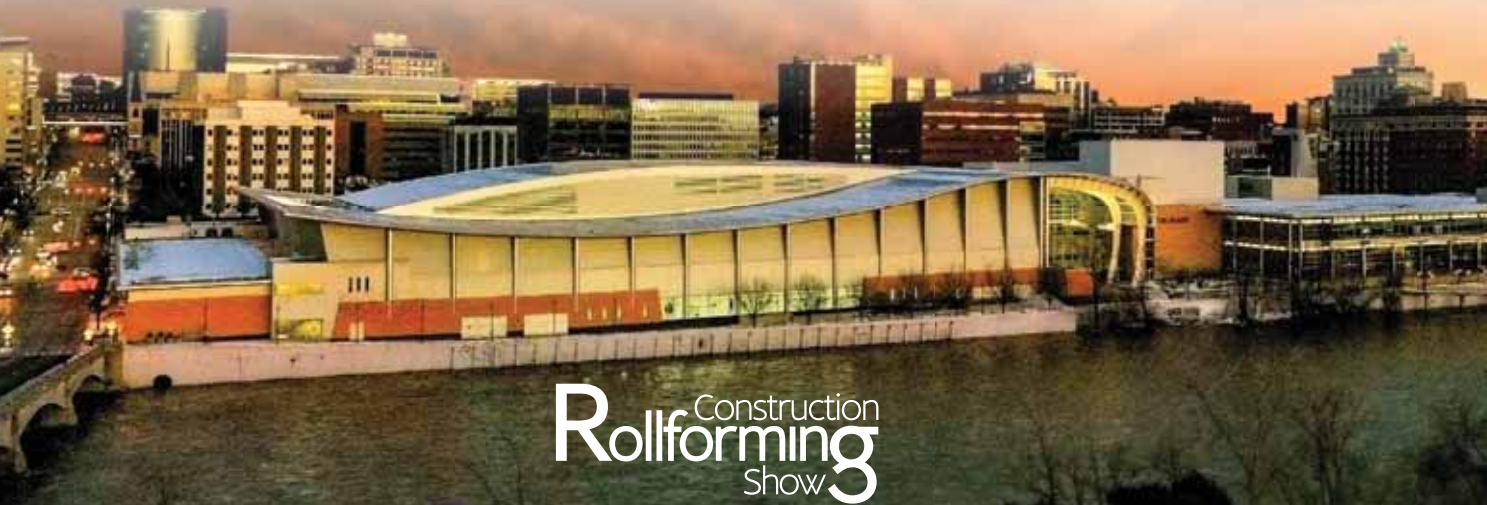

Construction
Rollforming
Show



Stoll Metal Works

Booth #209
 6600 Black Lane
 Waynesboro, PA 17268
 717-387-5572
 717-762-5670 (fax)

Stoll Metal Works is a growing business located in southern Pennsylvania. We offer low-tech affordable trim brakes, coil up-enders, flat stock tables and more for the metal roofing business. We can customize any of our machines to fit your needs.



Strongwall Columns

Booth #616
 8280 E Hwy. 60
 Irvington, KY 40146
 270-547-8827
 270-944-3035 (fax)

We offer 2x6/2x8 nail-laminated columns and metal anchor brackets for the post-frame industry.



SWI Machinery

Booth #301
 85 Howell Ave.
 Fairburn, GA 30213
 770-891-4388
 info@swimachinery.com
 www.swimachinery.com

SWI, an international leader in sheet metal machinery, utilizes state-of-the-art technology to drive our superior Marxman Automatic Slitting Machines, Recoilers and Uncoilers, including our CX5 Auto Decoiling & Storage System. Our machinery is fast, flexible, easy to operate and driven by manufacturing programming that fully integrates with company business

software. Advanced features maximize production while effective, reliable mechanical designs make SWI a number one choice for all sheet metal needs.



T&H Lemont, Inc.

Booth #421
 5118 Dansher Road
 Countryside, IL 60525
 708-482-1800
 sales@thlemont.com
 https://thlemont.com

The engineering staff at T&H Lemont, long known for its expertise in designing and building robust, innovative tube and pipe mills, likewise has a deep reservoir of roll forming knowledge. So if you need a machine for making roofing panels, ag panels, boards and battens, or items such as aprons, flashing, caps, drip edges or trim pieces, T&H Lemont delivers. Made in the USA.



Thomas Machinery Manufacturing Co. Ltd.

Booth #425
 South Section of No1. Road
 Economic Development Zone
 Botou City, Hebei Province,
 Rep. of China
 86 155 3281 7581
 elise@tgrollforming.com
 www.benthomas.cn.com

Thomas Company is a manufacturer of all kinds of roll forming machines. Custom is also supported.



Toolcrest LLC

Booth #313
 2510 S 250 W
 LaGrange, IN 46761
 260-463-2060
 sales@toolcrest.co

At Toolcrest, we specialize in high quality construction trailers. With our firsthand experience in construction, we understand the challenges you face in the industry. This is why we've equipped our trailers with organizable components, making the jobsite more efficient and streamlined. We build trailers with you in mind, so you can focus on what you do best. Designed to withstand the toughest conditions, Toolcrest trailers are Built-To-Last.



BECK Automation Integrate and Optimize Your Business with Beck Automation's Connex Software

- Connect and synchronize your roll forming machines, ERP software, and design software with ease.
- Streamline your production processes and eliminate manual data entry.
- Achieve greater efficiency, productivity, and accuracy throughout your operations.

Logos for Tekla, ACTBUILDING SYSTEMS, mbs, Connex, SAP, SAP One, NETSUITE, EPICOR, SYSPRO, ABIS, Microsoft Dynamics 365, and sage.

CRS Booth #522

sales@beckautomation.com / 314-576-9736



**Tough Trade Tools by
County Line Concepts**

Booth #422

11921 N Winans Road
Alma, MI 48801
989-859-2168
info@toughtradetools.com
www.ToughTradeTools.com

The construction business is a Tough Trade. Hard work, day and night. Estimates need to be done and projects need to be completed. Tough Trade Tools understands that and has developed tools to make your job more efficient, safer and accurate. Our Ridge-3:10 helps to accurately pre-punch holes in the metal panels, The Ridge-L series keeps angles accurate. These, along with our other innovative tools can be found at our website.



**Triangle Fastener
Corporation**

Booth #620

1925 Preble Ave.
Pittsburgh, PA 15233
800-486-1832
mgannon@trianglefastener.com
www.trianglefastener.com

TFC has been supplying the commercial construction industry with standard and specialty fasteners, tools, sealants, and accessories since 1977. From our 24 locations, we also specialize in providing hard-to-find items for critical applications. We have inventory and delivery programs that reduce waste and shorten lead times. We also offer engineering services from our TFC Tech Center and can custom design fasteners for your specific application.



Unist, Inc.

Booth #515

4134 36th St. SE
Grand Rapids, MI 49512
800-253-5462
salesupport@unist.com
www.unist.com

Since 1993, Unist has been a pioneer in precision lubrication systems for the metal forming industry. Our Uni-Roller® systems feature a patented internally fed roller design, providing an eco-friendly solution for applying lubricants to coil stock. Built on the concept of precise lubrication, Unist products reduce fluid usage, eliminate hazardous fluid messes, and increase efficiency with even and consistent fluid application.



**Steel Siding
with Wood Grain Print**

**2024
CRS
BOOTH #
220**

Printed Steel is gaining popularity in the metal industry. Graber Post Buildings is now stocking 4 different prints in wood grain printed coils. We offer roll-formed board and batten panels or coil stock for your siding machine. Giving the homeowner the attractive look of wood without the labor intensive upkeep of real wood!

- 26 Gauge - Grade 50
- Custom Slit Widths Available (13" Standard)
- 20 Year Print Warranty
- Print Matched Trim Components
- Realtree EDGE® Camo Also Available in 29 GA 41" Coil Stock





For More Information Scan Here:

800-262-5013 | info@graberpot.com | www.garberpost.com

**Digital Printed
AZ50 Galvalume
Wood Grain Options**



Rough Cedar Gray



Rough Cedar Aged



Hickory Natural



Rough Cedar Natural



United Steel Supply

Booth #401
 248 Addie Roy Road, Suite C200
 Austin, TX 78746
 512-263-0954
 www.unitedsteelsupply.com

Welcome to United Steel Supply, your first choice for steel. United Steel Supply provides high quality flat rolled steel coils. We offer superior customer service, competitive pricing and just-in-time delivery, allowing us to achieve the highest level of customer satisfaction. United Steel Supply furnishes Galvalume®, galvanized and prepainted steel coils for metal roofing and siding applications to the agricultural, commercial, industrial and residential markets. Brands: 22-, 24-, 26- and 29-ga. flat rolled 40-year painted coil inventory. Acrylic coated in 22-, 24-, 26- and 29-ga.



Van Mark Products Inc.

Booth #615
 24145 Industrial Park Dr.
 Farmington Hills, MI 48335
 248-478-1200
 sales@van-mark.com
 www.van-mark.com

Van Mark Products manufactures portable metal bending and forming tools for use in the siding and metal roofing industries. Offering a wide range of metal brakes, slitters, cutters, and other tools capable of manipulating up to 24-gauge painted steel on the jobsite. All products are designed, manufactured, and assembled in the USA and have been since 1964.



Wildcat LLC

Booth #619
 21868 Driftwood Blvd.
 Bloomfield, IA 52537
 888-308-7858
 sales@wildcatcompany.com
 www.wildcatcompany.com

Wildcat provides the best metal roofing fasteners all across the United States. With free shipping and no minimums on fasteners, we can get product to your business with your needs being our number one priority. Based in the Midwest, we are able to provide our customers with great lead times on all products. Great Service and Fantastic Fasteners! [RF](#)



SOLUTIONS FOR THE ROLLFORMING INDUSTRY



FELT APPLICATOR

ADJUSTABLE WIDE FORKS

COIL TIPPER

COIL RACKS

Bringing innovative solutions to the rollforming industry with superior quality and unparalleled efficiency.



Call for a **FREE** consultation on streamlining your rollforming processes
TOLL FREE PHONE: 88896-STAR1 PHONE 231-825-0163 FAX 231-825-0164



Fall for Fun in Grand Rapids

FAMILY FRIENDLY OUTINGS

The **John Ball Zoo** is always a great place to take kids, but new for 2024, they are introducing Dino Adventures to their Forest Realm. Over 20 life-size dinosaurs will visit, including a velociraptor, a triceratops, and even a T. Rex! These animatronic dinosaurs are programmed to display dinosaurs' real behaviors, such as mothering, feeding, preying, and more. Interactive elements like a fossil dig pit and T-Rex photo op will delight dino fans!

Other interactive experiences include animal trainings and feedings. Event schedule subject to change due to unforeseen events.

1300 W. Fulton St., Grand Rapids,
616-336-4300



An ambassador of the John Ball Zoo



Nick Irwin For Experience Gr. Artwork: Raining Wisdom By Abdoulaye Conde. Photos courtesy of Experience Grand Rapids, <https://www.experiencegr.com/>

ArtPrize, Grand Rapids' premier annual art festival is a wonderful cultural event for visitors of all ages. The downtown area will display 650 works of art from around the world. These artworks are a celebration of ideas, inclusiveness, and visual enjoyment. Everyone is welcome, free of charge. The festival runs from 9/12 to 9/28.

Frederik Meijer Gardens & Sculpture Park is Michigan's largest tropical conservatory with five themed gardens including the Japanese Garden and Michigan Farm Garden. 158 acres means there's a lot to explore. Displays are indoors and out and kids will especially love the Lena Meijer Children's Garden with the Great Lakes water feature, tree house village, storytelling garden, and more.

1000 E Beltline Ave. NE, Grand Rapids
616-957-1580

Grand Rapids Public Museum is fun, educational, and the place to head if the weather takes a turn. The museum features a 1928 carousel for children to ride, collections from A to Z including B for boxes, D for dolls, and J for Japan. Everyone will find a collection to love! Plus, you won't want to miss the planetarium or the Furniture Factory.

272 Pearl Street NW, Grand Rapids
616-929-1700

DINING WITH CHILDREN

Tupelo Honey Southern Kitchen & Bar is right in the neighborhood with from-scratch Southern style cooking. Customers like the chicken, meatloaf, and loaded potatoes. Family atmosphere and children's menu.

140 Ottawa Ave., NW, Suite 100, Grand Rapids
616-239-7158



Tupelo Honey's popular chicken sandwich

Brick and Porter is a downtown, pub-style restaurant offering sandwiches, salads, tacos, chicken, mac n' cheese, not to mention delightful desserts like lemon Italian cream cake, cookies and milk cake, raspberry donut cheesecake, and even rainbow sprinkle cake for the littlest little.

47 Monroe Center Street NW, Grand Rapids
616-226-6928

Grand Rapids Downtown Market is the way to go for the family who likes many choices. You will find everything from tacos to gumbo. There are great dessert choices as well: gourmet popcorn, ice cream, bakery, French pastries, and a soda shop with 500+ craft sodas.

435 Ionia Ave. SW, Grand Rapids
616-279-2670

Hancock serves up Nashville hot chicken and made from scratch picnic sides, all out of a remodeled, historic space. Children's menu and outdoor seating with games to play while you wait.

1157 Wealthy St. SE, Grand Rapids
616-805-4232

Yesterdog, a cash-only restaurant, has Grand Rapids' best hot dog, according to Grand Rapids Magazine. Their menu includes a krautdog, a chili cheddarog, chips, and with their build-your own dog option, you can have the flavor combo that's just right for you.

1505 Wealthy St. SE, Grand Rapids
616-336-0746

GETTING AROUND

The Downtown Area Shuttle, or DASH, is a free bus service that connects the downtown area. Call or check online to see the map.

616-456-3000,
<https://bit.ly/GRDASH24>

The Rapid Bus System is a pay system that takes you beyond the downtown area in Grand Rapids. Call or check online for further information.

616-776-1100, <https://www.ridetherapid.org/assets/files/1dp/schedule-book-summer-2024.pdf>

DINING EXPERIENCES ADULTS WILL LOVE

Leo's Seafood Restaurant & Bar presents seafood and classic cuisine along with a world-class wine list. Enjoy the formal dining room, the casual lounge and bar, or outdoor seating.

60 Ottawa Ave. NW, Grand Rapids
616-454-6700

San Chez A Tapas Bistro brings a blend of authentic European, Mediterranean, and Latin American cuisine in a fun, laid-back, and artful atmosphere. This adventurous menu includes seafood, chicken, vegetables, ham, and other traditional favorites prepared in intriguing dishes.

38 Fulton St. W, Grand Rapids
616-774-8272

Founders Brewery is nearby and ready to treat you to hand-crafted beer as well as hand-crafted delights such as sandwiches, bowls, salads, even kids' options.

235 Cesar E. Chavez Ave. SW, Grand Rapids
616-776-1195

Flanagan's Irish Pub features traditional Irish food and other pub favorites. Plus, you may be surprised by live music or karaoke night!

139 Pearl St. NW, Grand Rapids
616-719-1012



The Friesian Gastro Pub

Social House Kitchen & Bar celebrates Happy Hour every Wednesday to Friday from 2-6 p.m. with special prices on food and beverages. Appetizers, pizza, sandwiches, and bowls can be accompanied by beer, wine, and cocktails.

25 Ottawa Ave. SW, Grand Rapids
616 551 1412

The Friesian Gastro Pub features rooftop views of the downtown area in a casual neighborhood pub. Plus it boasts "an eclectic twist on comfort food." You'll feel on top of the world, whether you are enjoying a quiet dinner or crafted cocktails.

720 Michigan, Grand Rapids
616-825-3001

RF



The Carnivorous Plants House at Frederik Meijer Gardens & Sculpture Park

The Metal Shop's Success Keeps Growing

Your Service is Only as Strong as Your Worst Tool

■ By Linda Schmid

It all began with Emanuel Hershberger. He began his journey in the metal roofing industry at the age of 17 helping his dad in his construction business. At the age of 21 he established and opened his own metal roofing installation enterprise installing hundreds of metal roofs for homeowners and contractors in the Southern Tier of New York. Some of the projects included metal roofs for executives at Corning Glass and installing metal roofing at the Watkins Glen International Race Track. In 2012 Hershberger sold his business and moved back to Michigan

NEW DIRECTION

Upon relocating to Michigan in early 2013, he identified an opportunity for metal roofing within the predominantly traditional shingle roofing market. Drawing upon his decade of success and expertise, he embarked on a new venture alongside his wife, Esther, founding a roofing business in 2015. With a shared vision and collaborative effort, the business, Central Michigan Roofing, was born. However, it had its own set of challenges; the new market was a bit different from the New York market. Faced with difficulties in finding roofing supplies efficiently, they eventually decided to start roll forming their own panels. Initially, they used a New Tech machine to roll 1" standing seam panels and an MRS Pro-Rib machine for agricultural panels.

Recognizing that others might also struggle to obtain metal panels, Hershberger saw an opportunity to fill this gap in the market.

They began offering their panels to others and quickly discovered a significant demand. Consequently, they transitioned from installation services to full-time manufacturing of metal trim packages, and roofing and siding panels.

TOOLS FOR SUCCESS

To expand their product offerings, the company invested in an additional New Tech machine, a hemmer from Marion Manufacturing, a slit line from CIDAN Machinery, a board and batten machine from Eastside Machine Company, and a Variobend brake from Hershey's Metal Meister.

By 2019, their thriving operation had outgrown its original premises, prompting the construction of a new 22,000 sq. ft. facility. At the same time, they completely rebranded to closer align with their mission and vision. Thus, The Metal Shop was born.

Hershberger emphasized the importance of investing in new



The Metal Shop Team

machinery, selecting the best available tools to ensure high-quality service. He believes that a business is only as strong as its weakest tool, driving his commitment to choosing machines that provide the best performance and minimize downtimes.

Getting up to speed on new machines has been mixed he said. A couple of machines they struggled with at first, but the training they received from the manufacturers was, for the most part great, and service on the machines has been pretty good!

Hershberger is a hands-on guy, and he has a few guys on the team who are good problem-solvers, so if a manufacturer can't get out to the facility immediately, the team can usually figure it out between them. "We haven't had much downtime over the years," he said.

MARKETS SERVED

The Metal Shop services the entire state of Michigan, including shipping projects to the Upper Peninsula. Their customers primarily include the agricultural sector, pole buildings, and residential roofing projects. Over the years, they have also supplied commercial trim packages for projects such as hotels and storefront accents, for contractors, and also helped many DIY enthusiasts install their own projects.

Company offerings include a 36" 5-rib ag panel, multiple standing seam profiles, board and batten panels and trim packages, and all metal roofing and siding accessories.

Their customer base has been built primarily by word-of-mouth, which has kept them busy and fueled their growth.



Central Michigan Roofing

Recently, they invested in a Thalmann double folder from CIDAN Equipment, upgraded their old machine from Hershey's to a new one coming in 2025, and are planning further expansions to their facility.

EMPLOYEES AND PARTNERS

The company has nine employees currently, and Hershberger said that while finding the right employees has been hit and miss through the years, they have been blessed to find many great people who make up their current crew. They all pull together to create value for

their customers and try not be price-focused, ensuring they have the products their customers are looking for. They are all about forging long-term relationships with customers.

Over the years, The Metal Shop has established strong partnerships with Everlast Metals (now Progressive Metals) and Hixwood, sourcing the majority of their metal coils from these companies. Additionally, they offer a range of metal roofing tools from Malco Tools, along with various other suppliers who provide similar tools and accessories.

"SECRETS TO SUCCESS"

"There are no secrets to success," Hershberger said, "it requires a lot of hard work, long days, and sometimes even long nights. It takes grit. You need to stay true to your values and be honest with everyone."

That said, Hershberger does have some advice for people starting out. "If you don't have much experience, find people who do have experience and people who are smarter than you are and hire them," he said. "There is always someone who you can partner with, befriend, or hire that can help you with the answer."

Hershberger also emphasized the importance of having a personal reason for your business. For him, it's about helping others and the privilege of working with his family every day. His wife has always been part of the business, and his children are increasingly involved, growing into their roles each day.

The company is experiencing growth, and Hershberger hinted at some significant news to be announced in the fall.

"There are many niches and opportunities in roll forming and metal roofing right now," he added. "It's a great time to join the industry." RF

I'd absolutely recommend NTM machines to any business owner who's getting into rollforming."

— Mike Lemke
Lemke Exteriors in Moorehead, Minnesota

Mike Lemke, owner of Lemke Exteriors, boasts nearly three decades of experience in the metal roofing and gutter industry. With multiple NTM machines under his belt, including a WAV™ Wall Panel Machine, an SSQ II™ MultiPro Roof and Wall Panel Machine, and three Mach II™ Gutter Machines, Mike's business has flourished. Starting from a single machine operation, he now oversees a team of 25 employees and caters to high-end custom homes and commercial condos. Ready to grow your business like Mike? Contact us to learn how you can expand your operations with NTM!



HEAR MORE OF MIKE'S STORY

Scan the QR code to explore Mike's journey in the rollforming industry with NTM machines!





AKZONOBEL EXPANDING COIL COATINGS PRODUCTION IN NORTH AMERICA

AkzoNobel is investing \$3.6 million at its coil and extrusion coatings manufacturing facility in Garcia, Mexico, to increase production capacity and efficiency for its customers across North America — including Mexico and the southwest region of the U.S. This investment follows the previously announced \$70 million investments in the company's other industrial coatings manufacturing site in North America in Huron, Ohio, and its manufacturing and R&D facilities at High Point, North Carolina. These groundbreaking advancements support the company in achieving industrial excellence, enhancing product offerings and accelerating time-to-market. The investment in the Garcia site will enable the plant to increase production of coatings by approximately 35% by the third quarter of 2024.

Stage one of the investment has already been completed, with the installation of 12 new portable tanks with varying batch size capacity, two new mixers for portable tanks, and a new fixed tank with 1,200 gallons of capacity. The company's Garcia site in Mexico is one of its three coil and extrusion coatings-focused manufacturing facilities in North America, including Columbus, Ohio, which specializes in coil and extrusion coatings, and Huron, Ohio, a site producing the resins required for these coating systems. The site in Huron includes a recently completed pilot plant enabling more agility in meeting market demands. "Our customers are

increasingly prioritizing sustainability, durability and performance and demand for coil and extrusion coatings is projected to increase over the next few years. By expanding production and increasing efficiency at our facilities across North America and elsewhere, we're able to continue growing with our customers, whilst driving innovation and delivering high-quality products," said Manoel Rodrigues, AkzoNobel's Regional Commercial Director for Coil Americas.

MAJESTIC STEEL OPENS ARKANSAS SERVICE CENTER

Majestic Steel USA has announced the completion of its Arkansas service center and mass distribution facility. With four state-of-the-art processing lines fully operational and the facility strategically situated in the largest steel-producing region in the United States and on the Nucor Hickman campus, this milestone represents the beginning of a transformative journey in the steel industry.

Majestic Steel Arkansas comes fully equipped with the latest innovation and automation technology. Leveraging the precision engineering by two of the most trusted names in flat-rolled steel processing, Red Bud and Braner, the facility has dedicated slitting, cut-to-length, multi-blanking, and spin-down lines. These capabilities enable a comprehensive range of steel processing services to meet the evolving needs of its customers.

With a master coil storage capacity of 125,000 sq. ft. and a finished goods storage capacity of 122,000 sq. ft., within a specialized climate-controlled coil storage system, Majestic Steel Arkansas will have inventory on hand to meet immediate needs, adding reliability, stability, and efficiency to its customers' supply chain.

Majestic Steel Arkansas is a flagship, 513,633 sq. ft. service center and mass distribution facility. It's strategically located at the heart of the largest steel-producing region in the United States,

ensuring close proximity to customers and best-in-class supply sources. This allows Majestic Steel to optimize service levels and minimize costs.

Majestic Steel USA was founded in 1979 and headquartered in Cleveland, Ohio. It is a privately held and family owned distributor and processor of flat-rolled steel. Majestic serves its customers in manufacturing, construction, and distribution from its network of locations throughout North America.

MALCO TOOLS EARNS MINN. MANUFACTURING AWARD

Malco Tools, one of the nation's leading solution developers and manufacturers of a variety of high-quality tools for the HVAC and building construction trades, has been named a 2024 Minnesota Manufacturing Award winner from the Minneapolis/St. Paul Business Journal.

For the second time since 2018, Malco has been named Manufacturer of the Year in the medium-sized business category. The awards celebrate the successes and contributions of leading manufacturers to the region's economy.

Malco, which employs more than 150 associates at its plant in Annandale, is a 100% employee-owned employee stock ownership plan (ESOP) company. It aims to be a destination company in central Minnesota and has made many significant positive changes to the business to achieve this goal, including setting new company core values and an internal "Look Good, Feel Good, Do Good" campaign to renovate workspaces, promote employee collaboration and wellbeing, and give back to the community.

Since its last Manufacturer of the Year award win, the company has welcomed a new leadership team and strategic board members focused on driving measured and strategic growth, and strengthening the brand as it expands its product lines.

"Earning this recognition is such an honor, and an amazing way to celebrate the entire team's work over the years to strengthen our internal culture, improve processes and bring in strategic

experts to help guide our growth, all while maintaining our commitment to developing and manufacturing the highest quality tools for skilled trade pros,” said Rich Benninghoff, president and CEO at Malco. “We are immensely proud to once again be recognized among the leading manufacturers in the state of Minnesota who are doing fantastic work and promoting our local manufacturing industry.”

Malco is also a strong advocate for trade careers, donating significant quantities of in-kind products and apparel annually to national skilled trade education programs, competitions and events. Malco has also reached 85,000+ vocational students through its national “Head of the Class” Student Recognition Program, partnering with educators to recognize high-potential students and entire graduating classes in the trades.

Malco celebrates a safety-first culture, continuously maintaining its OSHA Safety and Health Achievement Recognition Program (MNSHARP) recognition since 2004, and earning the Minnesota Safety Council’s Governor’s Safety Award 13 times in the last 20 years.

Additionally, Malco is transitioning to environmentally-friendly recyclable packaging materials with significantly less plastic, reducing waste, conserving resources, and lessening its environmental impact.

METALCON ANNOUNCES 2024 KEYNOTE LINEUP

METALCON, the only global event dedicated exclusively to the application of metal in design and construction, announces its keynote speakers for this year’s annual conference and tradeshow in Atlanta from Oct 30.-Nov. 1, 2024.

Former National Football League Most Valuable Player and Super Bowl Champion quarterback, Joe Theismann, joins METALCON this year as the keynote speaker on Wednesday, October 30 at 9:00 a.m.

In his keynote, Theismann outlines the game plan that brought him success, both on and off the field. As an entrepreneur



Joe Theismann

and the former star quarterback for the Washington Redskins, he reveals his Game Plan for Success by drawing parallels between winning in football and in business.

Theismann’s career ended abruptly after sustaining a badly broken leg during a Monday Night Football game against the New York Giants on national television. An Emmy award winning analyst, entrepreneur, and athlete, he utilizes his gifts, talent and high energy to share his strategies with attendees for handling unforeseen change.

He focuses on how to succeed under pressure and how to adapt quickly



Dr. Anirban Basu

to unexpected situations. He urges individuals and organizations to set goals and correct errors each step of the way, an approach that builds momentum... which once on your side, would be hard for the best “defense” to stop.

Then, on Thursday, October 31 at 9:00 a.m., Dr. Anirban Basu, Chairman & CEO of Sage Policy Group, Inc., a Baltimore-based economic and policy consulting firm, presents The Good, The Bad, & The Ugly: Financial Outlook and Trends for Metal Construction.

Named one of Maryland’s 50 most influential people by Maryland newspaper, The Daily Record and one of



Our Integral Board and Batten machine revolutionizes wall panel production for residential and commercial use. With no need for clips or seaming, it ensures a seamless profile. Equipped with hydraulic drive, front hydraulic scissors shear, and a Digital Controller, it offers precise and easy operation. Adjustable panel width capability from 6” to 24” adds versatility. Experience the future of wall panel production with our Integral Board and Batten machine.

INTEGRAL BOARD & BATTEN MACHINE



NEW



jdumke@rollformerllc.com
www.rollformerllc.com
PH. 215-997-2511

the region's 20 most powerful business leaders by the Baltimore Business Journal, Basu will provide an in-depth analysis of major factors shaping economic outcomes, including interest rates, global geopolitical conflict, wage dynamics, business confidence, demographics, rising consumer debt levels and a presidential election — all conspiring to produce an economic downturn in 2025. He will provide a forecast for the coming year, highlighting the major risks that construction industry stakeholders will likely encounter and if 2025 should be a good year for the metal construction and design industry.

In 2014, Maryland Governor Larry Hogan appointed Basu Chair of the Maryland Economic Development Commission (2014-2021). Currently, he serves as Chairman of the Baltimore County Economic Advisory Committee. He also serves the chief economist function for the Associated Builders and Contractors, the Construction Financial Management Association, the Modular Building Institute, the Maryland Bankers Association, the International Food Distributors Association, and several others.

“We are thrilled to welcome Joe Theismann, a distinguished sports figure, and esteemed economist, Dr. Basu, as our keynote speakers this year,” said METALCON Show Director, Judy Geller. “Joe’s captivating life journey promises to ignite inspiration among attendees, while Dr. Basu’s profound insights into the economic landscape will provide invaluable foresight for the future of the metal construction and design industry.”

AMBASSADOR SUPPLY NAMES REGIONAL HUMAN RESOURCES MANAGER

Ambassador Supply has named Michelle Brundige as the company's regional human resources manager.

“We are excited to welcome Michelle to the team,” said Randy Carman, president of Ambassador Supply. “Her strong background in human resources and her involvement in the community in



Michelle Brundige, Ambassador Supply

multiple capacities make her a perfect fit for our company.”

Brundige’s career includes over 20 years in the human resources manufacturing industry, with a proven record in leading teams to maximize productivity, training and development. In her new role, Brundige is responsible for directing human resources functions for assigned Ambassador Supply companies, providing leadership and consultation to employees.

“I’m thrilled to be part of Ambassador Supply and work alongside their umbrella of companies in a human resources setting,” said Brundige. “Having a background in the manufacturing industry, I am confident that I can excel in this role while building the Ambassador Supply culture through the promotion of the company’s mission, purpose and core values.”

As Ambassador Supply continues to experience growth in the residential and commercial construction market, the company is recruiting driven professionals who thrive on thinking outside the box and have a strong understanding of the industry.

SENCO ANNOUNCES VP OF MARKETING AND SALES

KYOCERA SENCO Industrial Tools, Inc. (SENCO), a global leader



Tom Hodson, Kyocera Senco Industrial Tools

in pneumatic and cordless fastening solutions, has announced the promotion of Tom Hodson to the role of Vice President, Marketing and Sales, effective June 2024. In this position, Hodson will lead the continued development and execution of SENCO’s marketing, communications, and sales growth strategies.

“Tom has a vast understanding of SENCO’s products, people and capabilities and has used that to position SENCO as an industry leader in his areas of responsibility, and for that reason he has my confidence in this new role driving SENCO’s marketing and growth initiatives,” says Cliff Mentrup, CEO of KYOCERA SENCO Industrial Tools.

Hodson’s predecessor, Dave Moore, retired from the role in May.

Hodson has been with SENCO for 21 years, beginning as a territory sales manager. Prior to this appointment, he spent six years as SENCO’s Director of Channel Marketing & National Accounts where he was responsible for driving SENCO’s channel strategy and growing sales with national dealers and distributors. RF



For more titles, check out
Shield Wall Media online:
www.shieldwallmedia.com



UNITED STEEL SUPPLY

STEEL PRODUCTS FOR THE METAL ROOFING & METAL BUILDING INDUSTRY

Understanding Superior Service



512-263-0954 • unitedsteelsupply.com

WE ADD THE VALUE TO THE METAL



MARION MANUFACTURING



- Automation Systems
- Metal Construction Rollformers
- Coil Processing
- Forming & Fabrication
- Recondition Existing Machines

620-382-3751
www.marionmanufacturing.com



rFOIL® THE BEST WAY TO INSULATE METAL ROOFING



CLASS 1/A Fire Rating



888-887-3645
www.rFOIL.com

Manufactured by: **COVERTECH**

MANUFACTURER OF ROLL FORMING EQUIPMENT



- Coil Upenders • Shears • Slit Line • Uncoilers • Trim Roll Formers
- Wrappers • Panel Lines

Acu-Form
ROLL FORMING EQUIPMENT

Millersburg, Ohio
(330) 674-4003 - ACUFORMEQUIPMENT.COM

Golden Rule FASTENERS

**QUALITY PRODUCTS
COMPETITIVE PRICES
& MOST ORDERS SHIP THE SAME DAY**

- Screws • Closures • Ridge Vent
- Pipe Flashings • Butyl Tape • And much more!

Ph: (334) 283-4030 - FAX (334) 283-4032
info@goldenrulefastenersinc.com - www.goldenrulefastenersinc.com



Aztec Washer Company



MASTER FLASH®
ROOFING • PLUMBING • ELECTRICAL • HVAC • SOLAR

From the smallest to the LARGEST, the most complete line available.

Pipe Range: Fits: 1/8" to 39-1/2" Pipes
Base Range: 2-1/4" to 44" (1 meter)

1-800-WASHER 5 (927-4375) • Ph: 858-513-4350 • info@aztecwasher.com • www.aztecwasher.com



PSI Green Post™
Planet Saver Industries

THE MOST AFFORDABLE, ALL-IN-ONE SOLUTION FOR IN-GROUND POST DECAY AND UPLIFT RESTRAINT

P (610) 377-3270
www.planetsaverind.com

Made in the USA



Everlast Metals

ROOF AND WALL SYSTEMS



ASL NS
SSL DL

CONTACT EVERLAST METALS FOR QUICK SERVICE ON SLIT COIL, FLAT SHEETS AND ALL OF YOUR EXTERIOR METAL BUILDING COMPONENT NEEDS.

OFFERING:

- Heavy Gauge Painted Steel or Aluminum
- Solid or Vented FP & RP Panels
- Double Folder Capabilities for Custom Trim or Hard to Find Wall Panels
- Up to 26 Standard Fluoropon® Colors Available
- Quick Turn Around for Slit Coil
- Ready to Ship Fluoropon® and Polyester Aluminum Flat Sheets
- Eight Concealed Fastener Standing Seam Profiles

PLANT LOCATIONS:
Lebanon, PA Bridgton, ME
10 Enterprise Court 24 JR Mains Drive
Lebanon, PA 17042 Bridgton, ME 04009

FOR MORE INFORMATION CALL: 800-418-5057 OR VISIT US AT WWW.EVERLASTMETALS.COM



PREMIUM QUALITY ROLLFORMING MACHINERY

PANEL LINES **CZ PURLIN LINES**
TRIM LINES **CHANNEL LINES**
SLITTING LINES **ROLL UP DOOR LINES**

WWW.ASCMT.COM TEL: (509) 534-6600

REROOF WITH MORE INSULATION **NEW!!!**

FAST • EASY • LOW COST

Retrofit Clip

www.retrofitclip.com • retrofitclip@hotmail.com
 1-800-431-9661 • Manitoba, Canada

Steel Trusses

pole barns - riding arenas - ag structures - more

- ✓ Standard sizes in stock
- ✓ Engineer approved drawings
- ✓ Trusses up to 100' width

931-589-2386 buffaloivertruss.com

SPEEDLAP™
 Happy Jobsites!

CUT-TO-ORDER STEEL SOFFIT

EMAIL SALES@SPEEDLAP.COM TODAY!

Download Your Copy Of The Shield Wall Media Business Directory 2024:
www.shieldwallmedia.com/directory

Suppliers Index 2024
 HOW TO USE THIS GUIDE:
 This book is a quick, handy guide for anyone who is looking for suppliers and solutions for their business. It is a comprehensive directory of suppliers and solutions for the construction industry. This book is a valuable resource for anyone who is looking for suppliers and solutions for their business.

Rural Builder Directory 2024
 The Resource Book of Suppliers & Solutions
 • Suppliers Index
 • Company Listings
 PULL-OUT Industry Event Calendar PAGES 28-41

Directory 2024
 Find the suppliers with the products you need for your jobs... it's fast, it's easy, and it's at your fingertips!

To get your company into the 2025 Directory, use our online form or contact:

Gary Reichert • 715-252-6360 • gary@shieldwallmedia.com

DMI = BUILDING INVESTMENT PROTECTION



Let DMI complete your building project with Code Approved & Warrantied:

**HWH & PANCAKE FASTENERS • ANCHORS • PIPE FLASHINGS
REFLECTIVE INSULATION • POLYCARBONATE PANELS
SOLID & VENTED FOAM CLOSURES**

www.directmetalsinc.com 855-800-8878

SAMCO
People. Products. Passion.



Providing Complete Turnkey Roll Forming Solutions for Over 50 Years

**1 416 285 0619
www.samco-machinery.com**

RED T PRODUCTS

ULTRA-VENT
THE UNIVERSAL VENTILATION SYSTEM



40 YEAR WARRANTY!

833-473-3368
465 N Reading Rd,
Ephrata, PA 17522

HOURS:
Mon - Fri: 7 AM - 5 PM
Sat: By Appointment
Sun: Closed

5th ANNUAL
Construction Rollforming Show

SEPTEMBER 18-19, 2024
DeVos Place, Grand Rapids, MI

**FOR MORE INFORMATION CONTACT MISSY BEYER:
missy@shieldwallmedia.com • 920-216-3007**

DID YOU KNOW?

It costs less to buy a Business Card ad than it does to have cards printed. We even give your "cards" to more than 40,000 potential customers.



**Actual Card Size
(3.5" x 2")**

**FOR MORE INFO CONTACT GARY REICHERT:
gary@shieldwallmedia.com • 715-252-6360**

METAL ROOFING
MAGAZINE

Rollforming
Magazine

Rural Builder

GARAGE • SHED • CARPORT
BUILDER

FRAMEBUILDING
MAGAZINE

ROOFING ELEMENTS
MAGAZINE

Metal Builder

Rollforming

Magazine.com

YOUR ONLINE GUIDE TO ROLL FORMING



SCAN TO VIEW

Welcome to
rollformingmagazine.com

Steel Market Update

■ Courtesy of Majestic Steel USA

Each week, Majestic Steel USA [majesticsteel.com], a steel service center that distributes prime, flat-rolled galvanized steel sheets and coils to industries across the United States, compiles the Core Report. The Report is “an in-depth look at key indicators and trends driving the steel market. Market volatility demands your attention about what’s driving prices, when and why.” Data sources are listed in each section.

Majestic Steel has granted Rollforming Magazine permission to publish information excerpted from the Report for its readers.

DOMESTIC STEEL PRODUCTION

According to the American Iron & Steel Institute, Weekly Domestic Steel Production report dated June 28, domestic raw steel production increased the week before after sliding the previous two weeks. U.S. mills produced an estimated 1,710k tons at a 77.0% utilization rate; which is up from 1,704k tons and a 76.7% rate previously. Despite the increase, this was down 3% compared to the same period in 2023.

Production rose in three of the five regions, with the largest increase (in tons) coming from the Great Lakes region. Production from the Great Lakes region increased from 554k tons to 568k tons. Year-to-date production is now up 1.7% compared to the same period in 2023.

RECENT SCRAP PRICING

According to Prime Scrap for the week ending June 7: Mild demand, falling hot rolled prices, and thinning booked orders resulted in a drop of ferrous scrap metal prices in June. Prime scrap settled at \$380/gt, down \$40 from May and down over 25% since the beginning of 2024. Demand for scrap metal dropped in early June with Summer maintenance outages at Nucor Gallatin, Decatur, and Hickman mills, as well as NLMK’s Portage mill. Shredded scrap slipped \$20/gt to \$375/gt.

SPOT IRON ORE

The Platts, Spot Iron Ore report ending June 28, indicates that spot iron ore resumed its downward momentum, down four out of the last five weeks. Spot iron ore pricing settled at \$106.35/mt, down from \$107.50/mt the week prior. Chinese steel mills are holding back on iron ore purchases as China’s government plans to push steel output cuts this summer.

CARBON STEEL IMPORTS

According to the U.S. Census Bureau, Carbon Steel Imports report for May 2024: May preliminary carbon steel imports totaled 2.204 million tons, up 7.4% from April and up 29.6% from May 2023. This is the highest monthly total for carbon imports since June 2022.

Carbon flat rolled imports increased as well, climbing to 687,452 tons, up 0.8% from April and up 34.6% from 510,934 tons in May 2023.

While both hot rolled and cold rolled imports declined from April, they could not overcome the sharp increase in coated sheet imports. Coated sheet imports were up 19.7% from April and up 70.1% from May 2024.

On a daily rate, HDG imports (8,44k tons/day) were at their highest daily rate since March 2022.

Year-to-date carbon flat rolled imports are now up 41.3% compared to the first five months of 2023.

ZINC PRICE & INVENTORY

Based on the London Metal Exchange, Weekly Zinc Price and Inventory Report and the Shanghai Futures Exchange, Weekly Zinc Inventory Report, both dated June 28: Zinc pricing increased for the second consecutive week, ending the week at \$2,919/mt (\$1.324/lb), up from \$2,785.50/mt (\$1.263/lb) previously.

Despite the increase, zinc is still down nearly 7% since peaking at \$1.40/lb in late May.

Global zinc inventory decreased again, now down for the third consecutive week. LME warehouse inventory decreased from 244,375 metric tons to 239,600 metric tons. Shanghai warehouse inventory decreased from 128,107 metric tons to 126,413 metric tons.

The full library of Core Reports from Majestic Steel USA can be accessed at <https://www.majesticsteel.com/majestic-insights/core-report/>. **RF**

Partial Disclaimer: The Content herein is for informational purposes only and under no circumstances should it be (a) relied upon as advice or recommendations for any particular business or activity, or (b) construed as an offer to sell or a solicitation to buy any future contract, material, option, security or derivative including foreign exchange. All Content, graphics and trademarks incorporated in or forming a part of this report are owned by Majestic Steel USA, Inc. or its third party providers. All rights are reserved.

In no event shall Majestic Steel or any third party provider or any of their respective affiliates, officers, directors, employees, agents or licensors be liable to you or to anyone else for any direct, special, incidental, indirect, punitive, consequential damages or any other loss or injury caused in whole or in part by contingencies beyond their control or any negligence, including any gross negligence, in procuring, providing, compiling, interpreting, editing, writing, reporting, transmitting or delivering the Content.



CSI: Q2 vs. Q1 2024

After Receiving Mixed Anecdotal Reports, Roll Forming Survey Reflects Positive Market

We just came back from the first ever Post-Frame Builder Show. One of the great things is the opportunity to talk with builders, dealers, manufacturers and various professionals in our corner of the construction industry. One topic that always comes up is: “How is the industry doing?” Is business up or down, busy or slow, and what is next?

There are a lot of factors that can affect the business climate short term, especially in an election year. The general impression was that Q2 was slower than Q1, with no specific reasons given for the decrease. The story seemed similar across the various markets we serve.

Since we are generating data for the industry, this presented an excellent opportunity to validate or disprove what people were saying. We sent a survey on business climate comparing Q1 and Q2 in late June. The results were interesting.

Rollforming Magazine is about roll forming and metal forming so readers typically function at the dealer/distributor or manufacturer stage of the construction process.

Despite what we heard at the Post-Frame Builder Show, business is reportedly good for manufacturers and dealer/distributors.

Sales in dollars were generally up for Q2 vs. Q1 2024, and for Q2 2024 vs. Q2 2023. These generally were in keeping with expectations. **RF**

HOW DID YOUR GROSS SALES IN DOLLARS FOR Q2 2024 COMPARE TO Q1 2024?					
Which of these roles do you fill in the construction process?	Increased significantly (>25%)	Increased slightly (<25%)	Approx. the same	Decreased slightly (<25%)	Decreased significantly (>25%)
Builder, contractor or sub-contractor	33.33%	16.67%	16.67%	16.67%	16.67%
Material dealer, distributor or supplier	14.29%	42.86%	21.43%	14.29%	7.14%
Manufacturer	15.38%	53.85%	7.69%	15.38%	7.69%
HOW DID YOUR GROSS SALES IN DOLLARS FOR Q2 2024 COMPARE TO Q2 2023?					
Which of these roles do you fill in the construction process?	Increased significantly (>25%)	Increased slightly (<25%)	Approx. the same	Decreased slightly (<25%)	Decreased significantly (>25%)
Builder, contractor or sub-contractor	33.33%	16.67%	16.67%	16.67%	16.67%
Material dealer, distributor or supplier	28.57%	28.57%	14.29%	21.43%	7.14%
Manufacturer	23.08%	30.77%	0%	38.46%	7.69%
HOW DID YOUR GROSS SALES IN DOLLARS FOR Q2 2024 COMPARE TO YOUR EXPECTATIONS?					
Which of these roles do you fill in the construction process?	Increased significantly (>25%)	Increased slightly (<25%)	Approx. the same	Decreased slightly (<25%)	Decreased significantly (>25%)
Builder, contractor or sub-contractor	33.33%	0%	16.67%	50%	0%
Material dealer, distributor or supplier	14.29%	14.29%	28.57%	35.71%	7.14%
Manufacturer	23.08%	7.69%	38.46%	30.77%	0%

GET MORE INFORMATION ABOUT PRODUCTS & SERVICES SEEN IN THIS ISSUE. HERE'S HOW:



If you are looking for more information from companies featured in this issue, fill out this form.

Mail the completed form to us, and we will have those companies get in touch with you. There's no need to fill out multiple forms; we'll do the legwork for you.

Name (please print) _____

Signature (required) _____

Company _____

Address _____

City _____ State _____ Zip _____

Telephone (_____) _____

E-mail _____ Date _____

Please check one or more boxes to subscribe FREE/Renew for 3 years:

- Garage, Shed & Carport Builder Magazine*
 Frame Building News
 Metal Roofing Magazine
 Rural Builder
 Rollforming Magazine
 Roofing Elements Magazine
 Metal Builder

I would like to receive my subscription: By Mail Digitally

Check this box if you wish to receive our Construction Express newsletter and offers from our partners.

Email address is required to receive newsletter.

CONTACT NAME & EMAIL (OR) NAME & PHONE NUMBER ARE REQUIRED. WITHOUT THIS INFORMATION WE WILL NOT PROCESS THE REQUEST.

CHECK WHICH TITLE APPLIES TO YOU:

- President
- Owner
- Partner
- General Manager
- Sales Manager/Rep
- Engineer/Architect
- Vice President
- Foreman
- Installer
- Other _____

PLEASE CHECK THE PRIMARY CATEGORY THAT DESCRIBES YOUR BUSINESS:

- Builder, Dealer, Remodeler or Installer
- Roofing Contractor
- Metal Roofing Contractor
- Building Material Dealer/Distributor
- General Contractor/Remodeler
- Manufacturer/Rep of Manufacturer
- Architect/Specifier
- Construction Consultant/Engineer
- Building Owner/Developer
- Other (Please Specify) _____

ENGAGED IN THE FOLLOWING APPLICATIONS:

- Gutters/Accessories
- Institutional
- Residential
- Agricultural
- Commercial
- Industrial

SELECT A MAXIMUM OF 5 COMPANIES TO REQUEST INFORMATION FROM:

Company Name: _____ PAGE: _____

Company Name: _____ PAGE: _____

Company Name: _____ PAGE: _____

Company Name: _____ PAGE: _____

Company Name: _____ PAGE: _____

I understand that by providing the above information I hereby consent to receive communication regarding my subscription via US Mail, telephone, and e-mail sent by *Rollforming Magazine*.

RF August/September 2024